

Scotsman[®]

SERVICE MANUAL

AC-EC 106

AC-EC 126

AC-EC 176

AC-EC 206

AC-EC 226

R134A - R404A - R452A version

**Electronic cubers with storage
PC Board version**

Scotsman Ice Srl
Via Lainate, 31 - 20010 Pogliano M.se - Milano - Italy
Tel. +39-02-93960.1 (Aut. Sel.)- Telefax +39-02-93550500
Direct Line to Service & Parts:
Phone +39-02-93960350 - Fax +39-02-93540449
Website: www.scotsman-ice.it
E-Mail: scotsman.europe@scotsman.it



REV. 05/2019

INDICE

Table of contents	page	2
Specifications AC-EC 106		3
Specifications AC-EC 126		6
Specifications AC-EC 176		9
Specifications AC-EC 206		12
Specifications AC-EC 226		15

GENERAL INFORMATION AND INSTALLATION

Introduction	17
Unpacking and Inspection	17
Location and levelling	17
Electrical connections	17
Water supply and drain connections	18
Final check list	18
Installation practice	19

OPERATING INSTRUCTIONS

Start up	20
Operational checks	21

OPERATING PRINCIPLES (How it works)

Freezing cycle	26
Harvest cycle	29
Electrical sequence	30
Components description	34

ADJUSTMENT, REMOVAL AND REPLACEMENT PROCEDURES

Adjustment of the cube size	39
Wiring diagram AC-EC 106-126-176-206-226	40
Service diagnosis	42

MAINTENANCE AND CLEANING INSTRUCTIONS

General	45
Icemaker	45
Clean - Replace of air condenser filter	45
Cleaning instructions of water system	45

SPECIFICATIONS

ELECTRONIC CUBER MODEL AC-EC 106

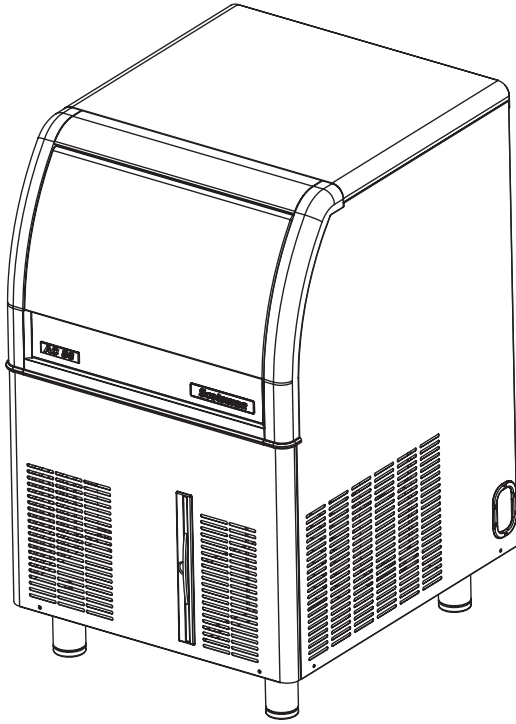

Important operating requirements:

	MIN.	MAX.
Air temperature	10°C	40°C
Water temperature	5°C	35°C
Water pressure	1 bar	5 bar
Electr. voltage variations from voltage rating specified on nameplate	-10%	+10%

ice making capacity

AIR COOLED MODELS

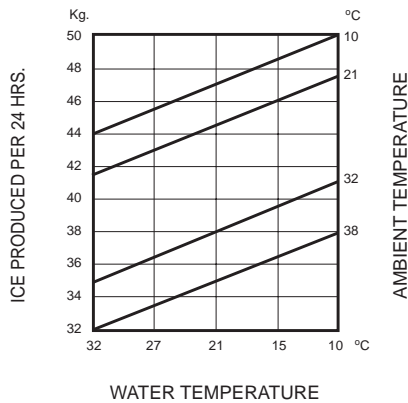

WATER COOLED MODELS

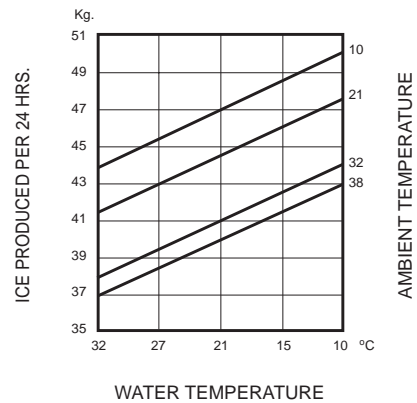

NOTE. With the unit in "built-in" conditions, the ice production is gradually reduced in respect to the levels shown in the graf, up to a maximum of 10% at room temperatures higher than 32°C. The daily ice-making capacity is directly related to the condenser air inlet temperature, water temperature conditions of the condenser air filter and age of the machine. To keep your SCOTSMAN CUBER at peak performance levels, periodic maintenance checks must be carried out as indicated on Maintenance and Cleaning section of this manual.

SPECIFICATIONS

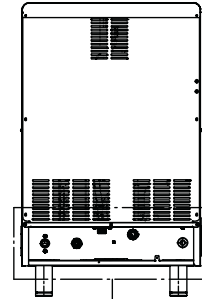
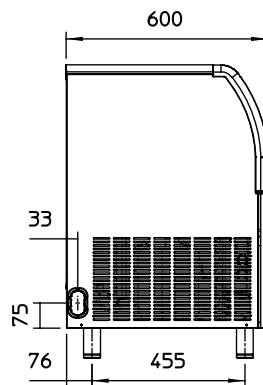
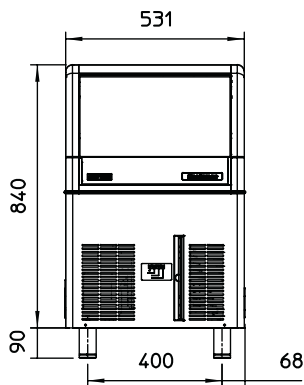

AIR FLOW

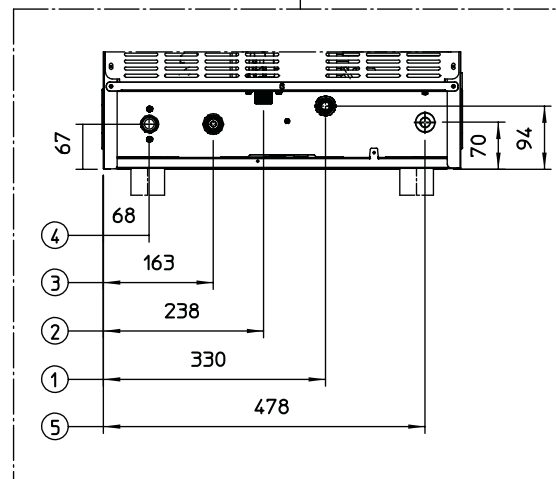
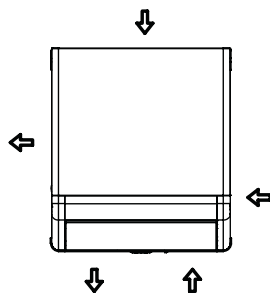

- 1 25/32" OD - OVERFLOW DRAIN
- 2 3/4" GAS WATER INLET
- 3 3/4" GAS WATER OUTLET - WATER COOLED UNIT ONLY
- 4 3/4" GAS WATER INLET - WATER COOLED UNIT ONLY
- 5 CORD SET

**AC 106 - CUBER
machine specifications**

Model	Cond. unit	Finish	Comp. HP	Bin Capacity	Water req. lt/24 HR	
AC 106 AS AC 106 WS	Air Water	Stainless steel	1/3	23 Kg.	144* NYA	
Basic electr.	Amps	Start Amps	Watts	Electric power cons. Kwh per 24 Hr	Nr. of wires	Amps fuse
230/50/1	3.2	20	580	10.2	3 x 1.5 mm ²	10
				NYA		
Cubes per harvest: 32 medium						
* At 32/21 °C amb.-water						

SPECIFICATIONS

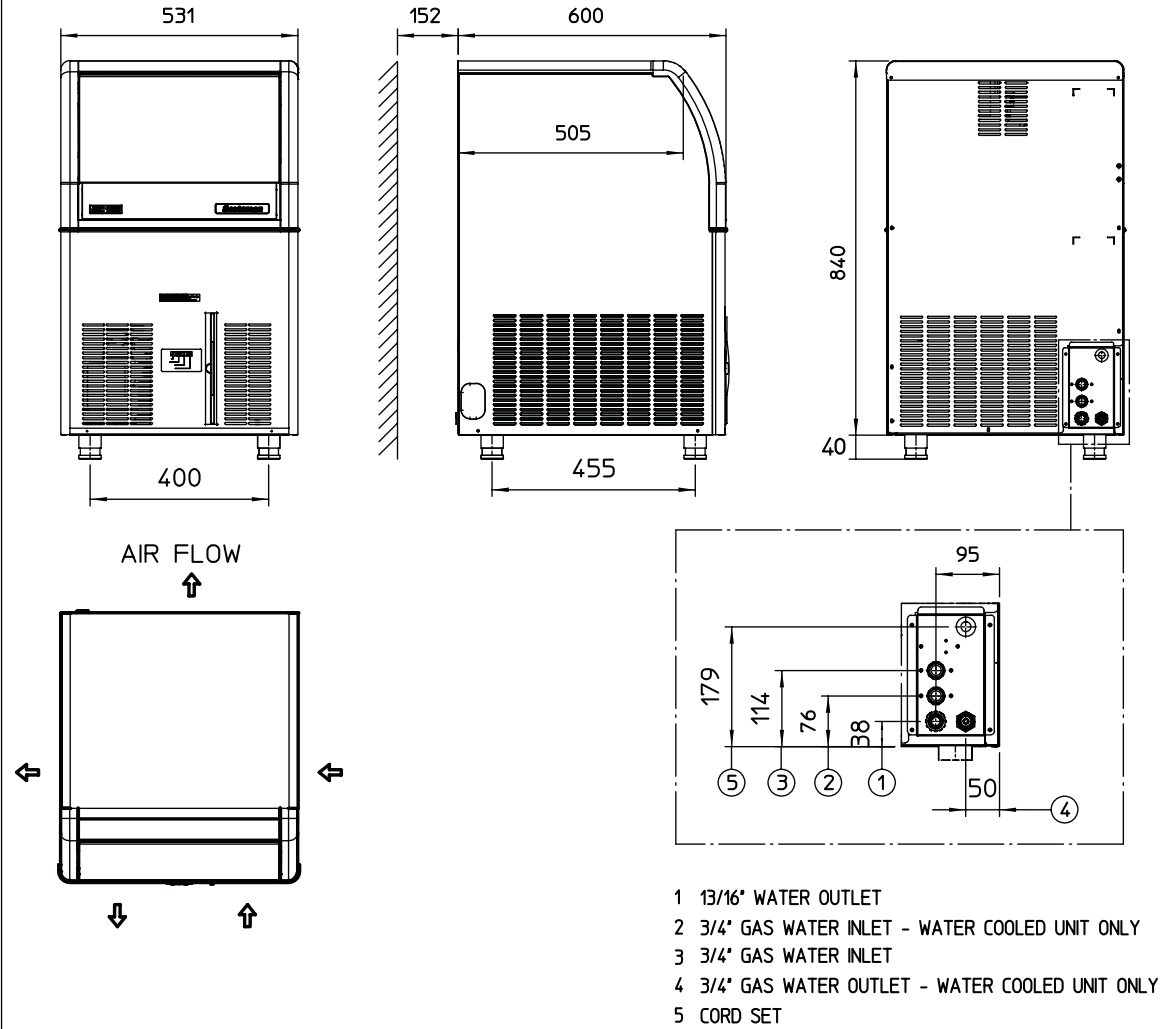

- 1 13/16" WATER OUTLET
- 2 3/4" GAS WATER INLET - WATER COOLED UNIT ONLY
- 3 3/4" GAS WATER INLET
- 4 3/4" GAS WATER OUTLET - WATER COOLED UNIT ONLY
- 5 CORD SET

**EC 106 - CUBER
machine specifications**

Model	Cond. unit	Finish	Comp. HP	Bin Capacity	Water req. lt/24 HR	
EC 106 AS EC 106 WS	Air Water	Stainless steel	1/3	23 Kg.	144* NYA	
Basic electr.	Amps	Start Amps	Watts	Electric power cons. Kwh per 24 Hr	Nr. of wires	Amps fuse
230/50/1	3.2	20	580	10.2	3 x 1.5 mm ²	10
				NYA		
Cubes per harvest: 32 medium						
* At 32/21 °C amb.-water						

SPECIFICATIONS

ELECTRONIC CUBER MODEL AC-EC 126

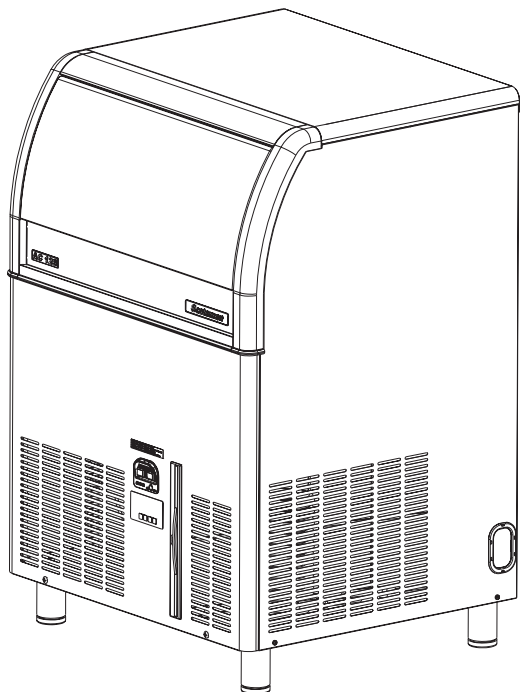

Important operating requirements:

	MIN.	MAX.
Air temperature	10°C	40°C
Water temperature	5°C	35°C
Water pressure	1 bar	5 bar
Electr. voltage variations from voltage rating specified on nameplate	-10%	+10%

ice making capacity

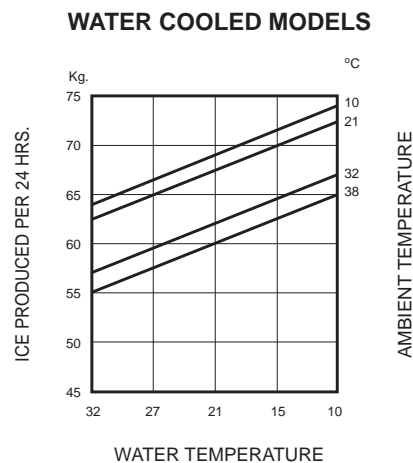
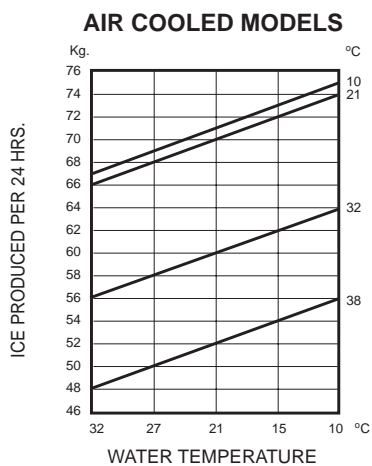

NOTE. With the unit in "built-in" conditions, the ice production is gradually reduced in respect to the levels shown in the graf, up to a maximum of 10% at room temperatures higher than 32° C. The daily ice-making capacity is directly related to the condenser air inlet temperature, water temperature conditions of the condenser air filter and age of the machine. To keep your SCOTSMAN CUBER at peak performance levels, periodic maintenance checks must be carried out as indicated on Maintenance and Cleaning section of this manual.

SPECIFICATIONS

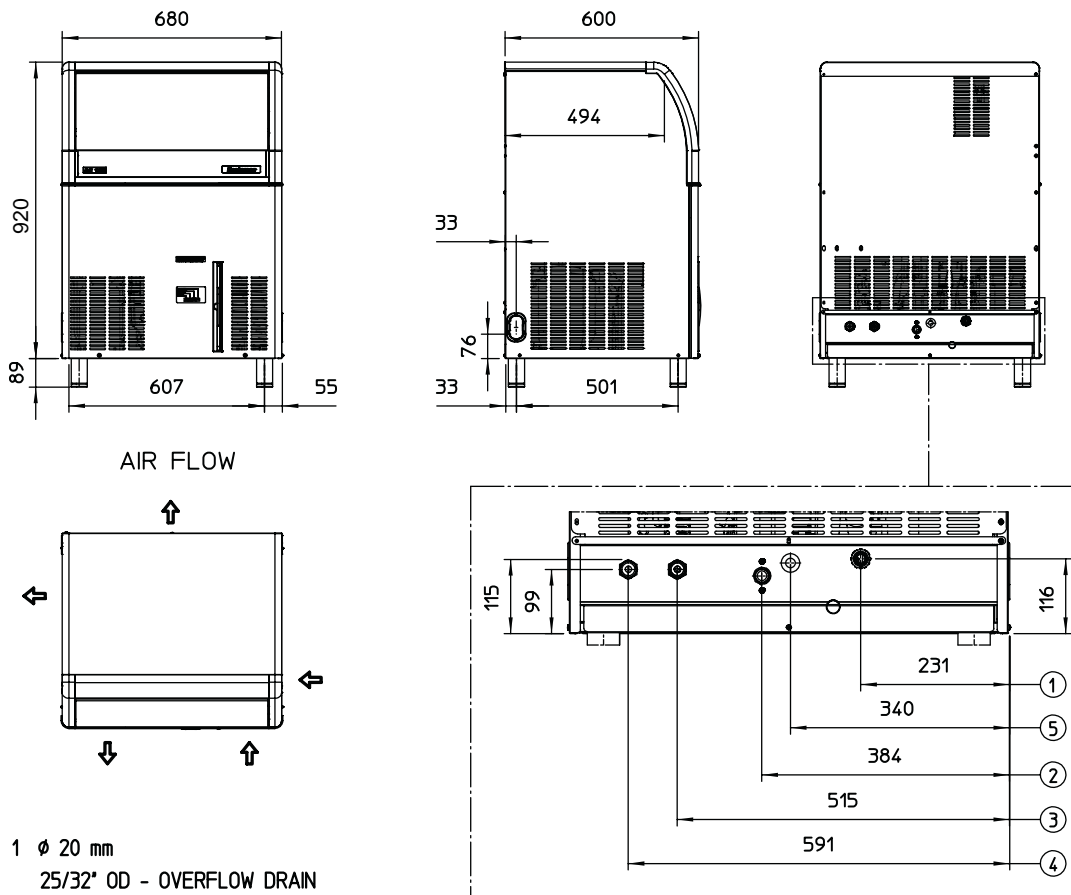

- 1 ϕ 20 mm
25/32" OD - OVERFLOW DRAIN
- 2 3/4" GAS
3/4" GAS WATER INLET
- 3 3/4" GAS
3/4" GAS WATER OUTLET - WATER COOLED UNIT ONLY
- 4 3/4" GAS
3/4" GAS WATER INLET - WATER COOLED UNIT ONLY
- 5 CORD SET

Dimensions:
 HEIGHT (without legs) 920 mm.
 HEIGHT (with legs) 1010 mm.
 WIDTH 680 mm.
 DEPTH 600 mm.
 WEIGHT 75 Kgs.

**AC-EC 126 - CUBER (R404A version)
 machine specifications**

Model	Cond. unit	Finish	Comp. HP	Bin Capacity	Water req. lt/24 HR	
AC-EC 126 AS AC-EC 126 WS	Air Water	Stainless steel	1/2	39 Kg.	136 810*	
Basic electr.	Amps	Start Amps	Watts	Electric power cons. Kwh per 24 Hr	Nr. of wires	Amps fuse
230/50/1	3.7	19	740	13.8	3 x 1.5 mm ²	10
			580	12.3		

Cubes per harvest: 56 medium
 * At 32°C ambient - 21°C water temperature

SPECIFICATIONS

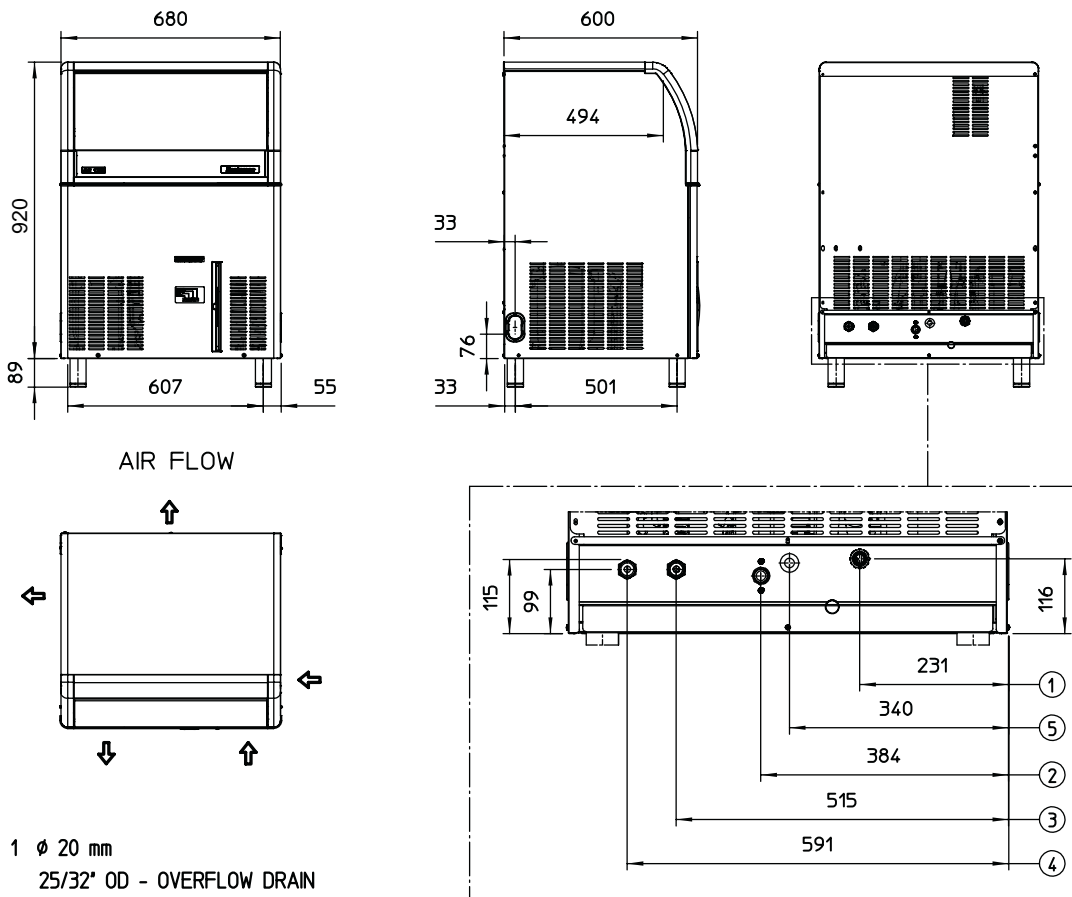

- 1 ϕ 20 mm
25/32" OD - OVERFLOW DRAIN
- 2 3/4" GAS
3/4" GAS WATER INLET
- 3 3/4" GAS
3/4" GAS WATER OUTLET - WATER COOLED UNIT ONLY
- 4 3/4" GAS
3/4" GAS WATER INLET - WATER COOLED UNIT ONLY
- 5 CORD SET

Dimensions:

HEIGHT (without legs) 920 mm.
 HEIGHT (with legs) 1010 mm.
 WIDTH 680 mm.
 DEPTH 600 mm.
 WEIGHT 75 Kgs.

**AC-EC 126 - CUBER (R134A version from s.n. 09013)
 machine specifications**

Model	Cond. unit	Finish	Comp. HP	Bin Capacity	Water req. lt/24 HR	
AC-EC 126 AS AC-EC 126 WS	Air Water	Stainless steel	1/2	39 Kg.	266 1248*	
Basic electr.	Amps	Start Amps	Watts	Electric power cons. Kwh per 24 Hr	Nr. of wires	Amps fuse
230/50/1	5.3	26	900	16.7	3 x 1.5 mm ²	10
			730	15.2		
Cubes per harvest: 56 medium						
* At 32°C ambient - 21°C water temperature						

SPECIFICATIONS

ELECTRONIC CUBER MODEL AC-EC 176

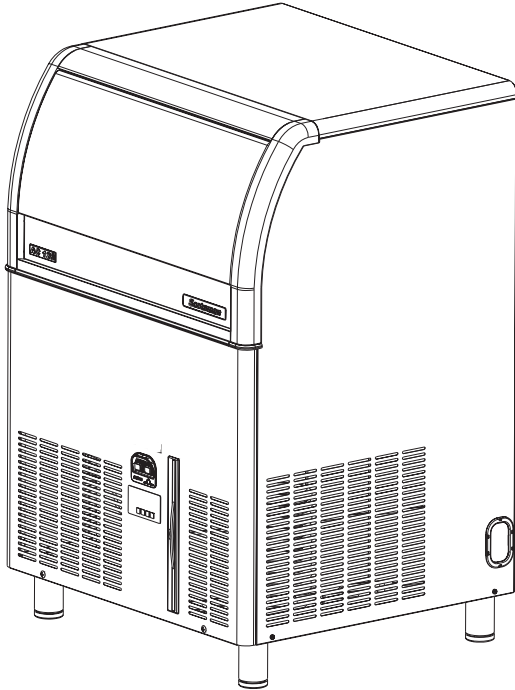

Important operating requirements:

	MIN.	MAX.
Air temperature	10°C	40°C
Water temperature	5°C	35°C
Water pressure	1 bar	5 bar
Electr. voltage variations from voltage rating specified on nameplate	-10%	+10%

ice making capacity

AIR COOLED MODELS

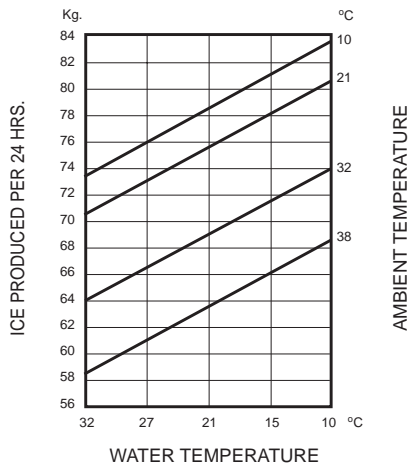

WATER COOLED MODELS

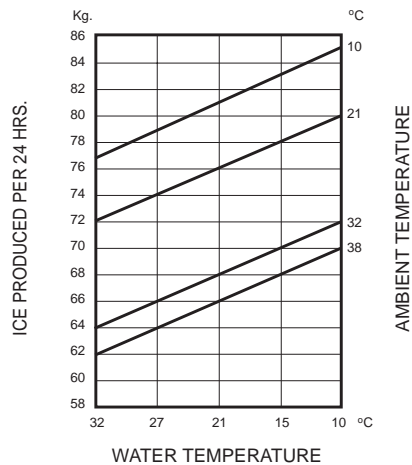

NOTE. With the unit in "built-in" conditions, the ice production is gradually reduced in respect to the levels shown in the graf, up to a maximum of 10% at room temperatures higher than 32° C. The daily ice-making capacity is directly related to the condenser air inlet temperature, water temperature conditions of the condenser air filter and age of the machine. To keep your SCOTSMAN CUBER at peak performance levels, periodic maintenance checks must be carried out as indicated on Maintenance and Cleaning section of this manual.

SPECIFICATIONS

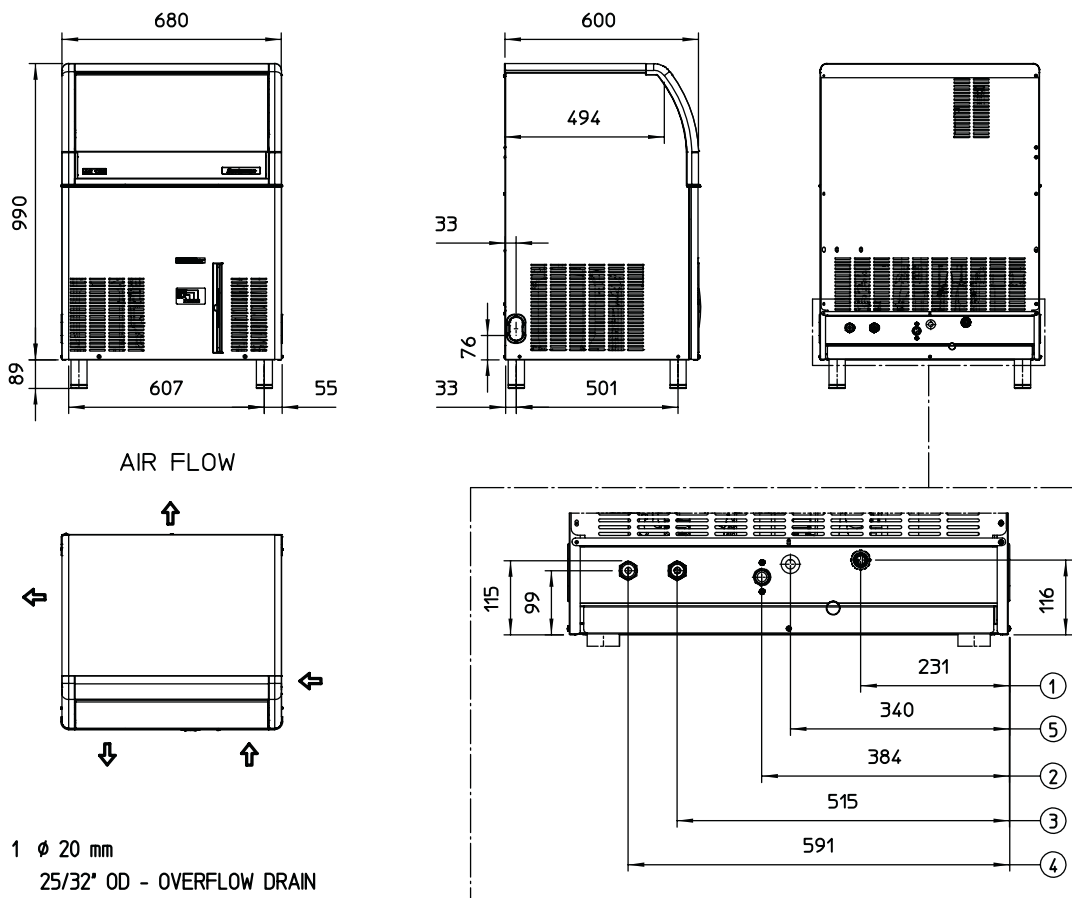

- 1 ϕ 20 mm
25/32" OD - OVERFLOW DRAIN
- 2 3/4" GAS
3/4" GAS WATER INLET
- 3 3/4" GAS
3/4" GAS WATER OUTLET - WATER COOLED UNIT ONLY
- 4 3/4" GAS
3/4" GAS WATER INLET - WATER COOLED UNIT ONLY
- 5 CORD SET

Dimensions:
 HEIGHT (without legs) 990 mm.
 HEIGHT (with legs) 1090 mm.
 WIDTH 680 mm.
 DEPTH 600 mm.
 WEIGHT 80 Kgs.

**AC-EC 176 - CUBER (R404A version)
 machine specifications**

Model	Cond. unit	Finish	Comp. HP	Bin Capacity	Water req. lt/24 HR
AC-EC 176 AS AC-EC 176 WS	Air Water	Stainless steel	3/4	48 Kg.	170 950*

Basic electr.	Amps	Start Amps	Watts	Electric power cons. Kwh per 24 Hr	Nr. of wires	Amps fuse
230/50/1	5.2	19.4	900	16.7	3 x 1.5 mm ²	16
	4.3		610	14		

Cubes per harvest: 56 medium
 * At 32°C ambient - 21°C water temperature

SPECIFICATIONS

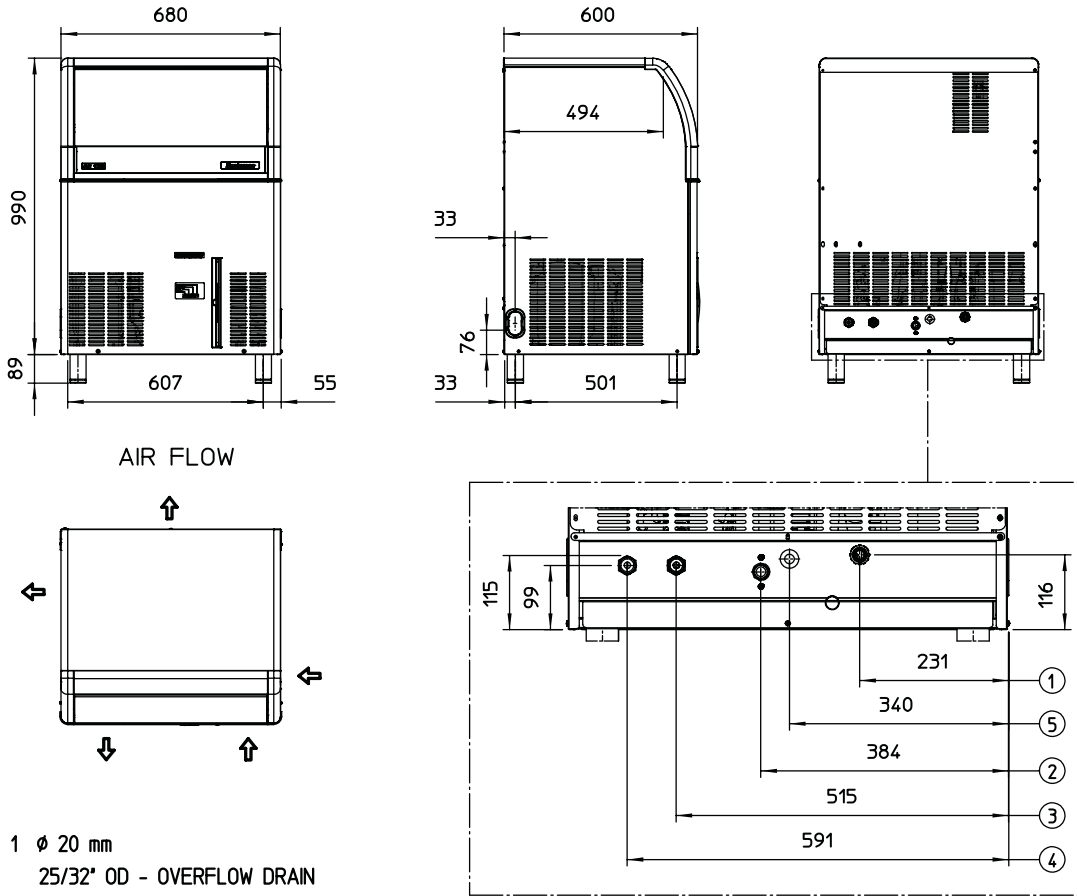

- 1 ϕ 20 mm
25/32" OD - OVERFLOW DRAIN
- 2 3/4" GAS
3/4" GAS WATER INLET
- 3 3/4" GAS
3/4" GAS WATER OUTLET - WATER COOLED UNIT ONLY
- 4 3/4" GAS
3/4" GAS WATER INLET - WATER COOLED UNIT ONLY
- 5 CORD SET

Dimensions:
 HEIGHT (without legs) 990 mm.
 HEIGHT (with legs) 1079 mm.
 WIDTH 680 mm.
 DEPTH 600 mm.
 WEIGHT 70 Kgs.

**AC-EC 176 - CUBER (R134A version from s.n. 14409)
 machine specifications**

Model	Cond. unit	Finish	Comp. HP	Bin Capacity	Water req. lt/24 HR	
AC-EC 176 AS AC-EC 176 WS	Air Water	Stainless steel	5/8	48 Kg.	204 1488*	
Basic electr.	Amps	Start Amps	Watts	Electric power cons. Kwh per 24 Hr	Nr. of wires	Amps fuse
230/50/1	6.5	29	1000	18.5	3 x 1.5 mm ²	16
	6		800	18		

Cubes per harvest: 56 medium
 * At 32°C amb. / 21°C water temperature

SPECIFICATIONS

ELECTRONIC CUBER MODEL AC/EC 206

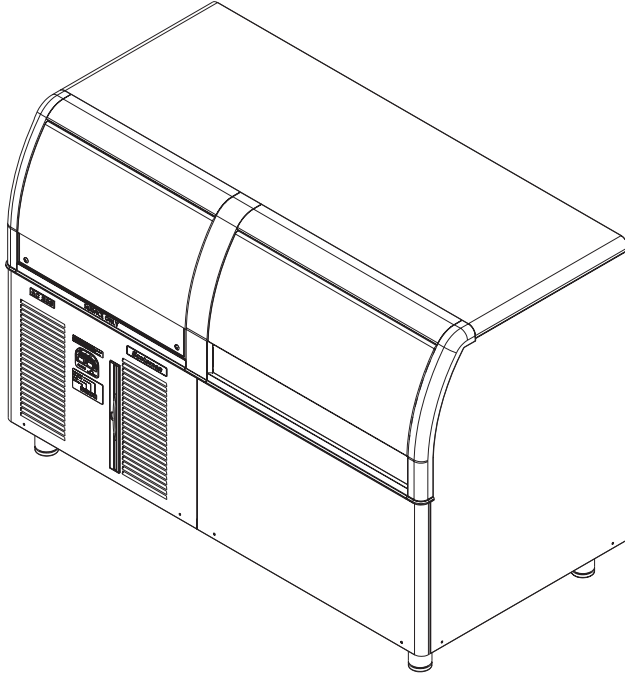

Important operating requirements:

	MIN.	MAX.
Air temperature	10°C	40°C
Water temperature	5°C	35°C
Water pressure	1 bar	5 bar
Electr. voltage variations from voltage rating specified on nameplate	-10%	+10%

ice making capacity

AIR COOLED MODELS

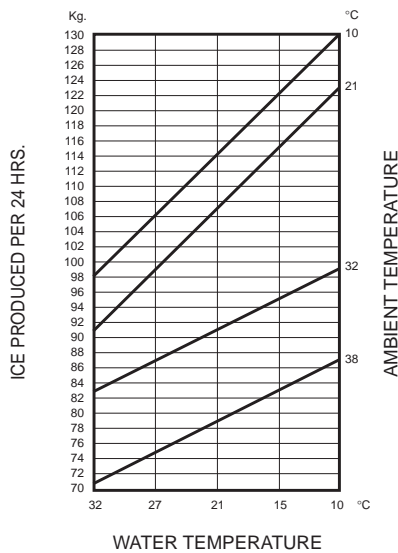

WATER COOLED MODELS

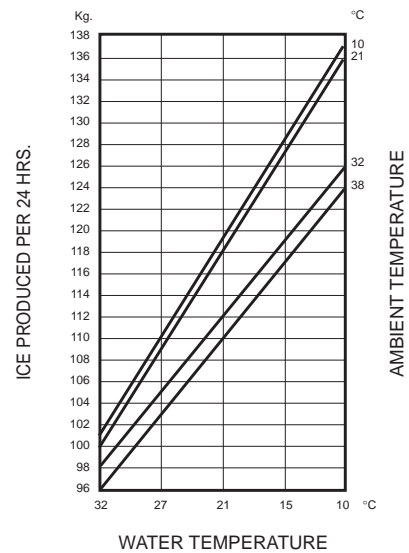

NOTE. The daily ice-making capacity is directly related to the condenser air inlet temperature, water temperature conditions of the condenser air filter and age of the machine. Production charts shown indicate the production of ACM models; ice production of ACL and ACS models is 10% lower. To keep your SCOTSMAN CUBER at peak performance levels, periodic maintenance checks must be carried out as indicated on Maintenance and Cleaning section of this manual.

SPECIFICATIONS

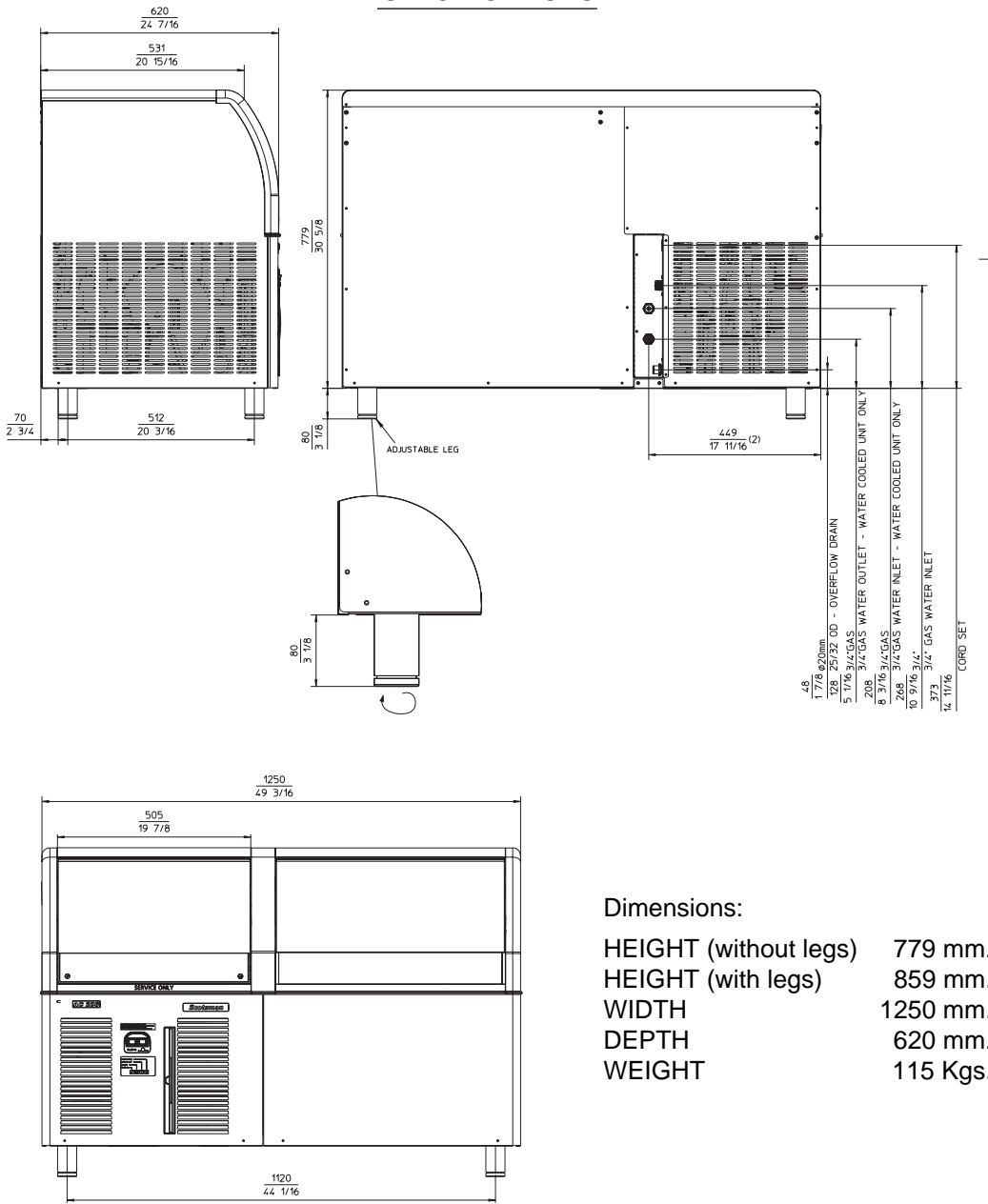

Dimensions:
 HEIGHT (without legs) 779 mm.
 HEIGHT (with legs) 859 mm.
 WIDTH 1250 mm.
 DEPTH 620 mm.
 WEIGHT 115 Kgs.

**AC/EC 206 - CUBER (R404A version)
 machine specifications**

Model	Cond. unit	Finish	Comp. HP	Bin Capacity	Water req. lt/24 HR	
AC/EC 206 AS AC/EC 206 WS	Air Water	Stainless steel	1/2	50 Kg.	280 1400*	
Basic electr.	Amps	Start Amps	Watts	Electric power cons. Kwh per 24 Hr	Nr. of wires	Amps fuse
230/50/1	4.7	19	950	20.8	3 x 1.5 mm ²	16
				17.3		
Cubes per harvest: 72 large / 106 medium / 198 small * At 32°C amb. / 21°C water temperature						

SPECIFICATIONS

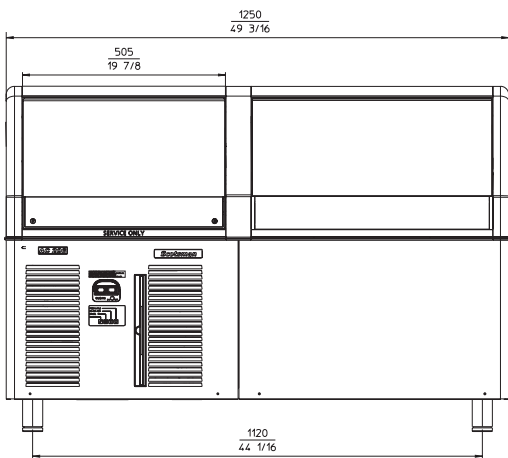
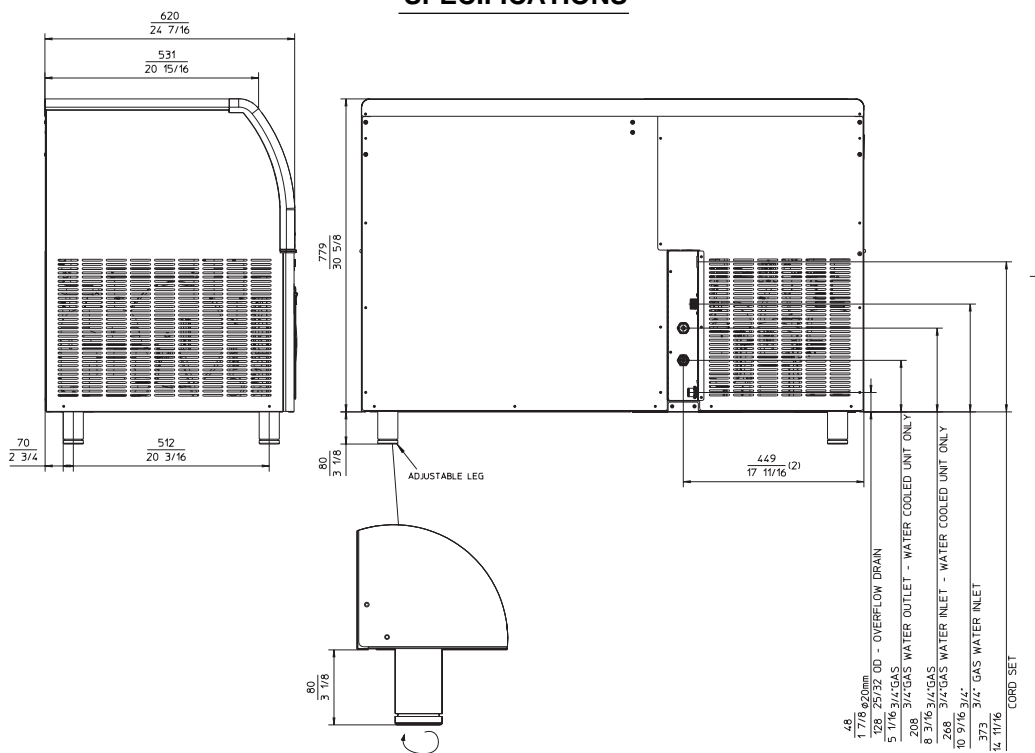

Dimensions:
 HEIGHT (without legs) 779 mm.
 HEIGHT (with legs) 859 mm.
 WIDTH 1250 mm.
 DEPTH 620 mm.
 WEIGHT 115 Kgs.

**AC/EC 206 - CUBER (R452A version)
 machine specifications**

Model	Cond. unit	Finish	Comp. HP	Bin Capacity	Water req. lt/24 HR
AC/EC 206 AS AC/EC 206 WS	Air Water	Stainless steel	1/2	50 Kg.	336 1932*

Basic electr.	Amps	Start Amps	Watts	Electric power cons. Kwh per 24 Hr	Nr. of wires	Amps fuse
230/50/1	4	19.3	850	18.4	3 x 1.5 mm ²	16
	4.2		680	16.5		

Cubes per harvest: 72 large / 106 medium / 198 small
 * At 32°C ambient / 21°C water temperature

SPECIFICATIONS

ELECTRONIC CUBER MODEL AC/EC 226

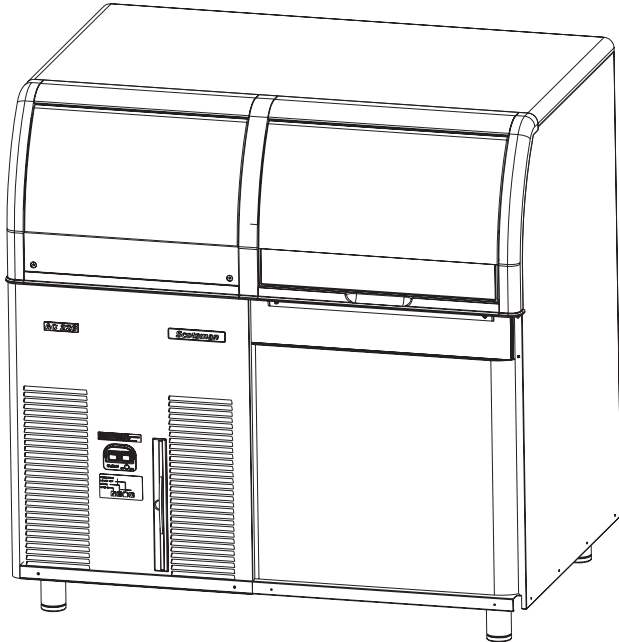

Important operating requirements:

	MIN.	MAX.
Air temperature	10°C	40°C
Water temperature	5°C	35°C
Water pressure	1 bar	5 bar
Electr. voltage variations from voltage rating specified on nameplate	-10%	+10%

ice making capacity

AIR COOLED MODELS

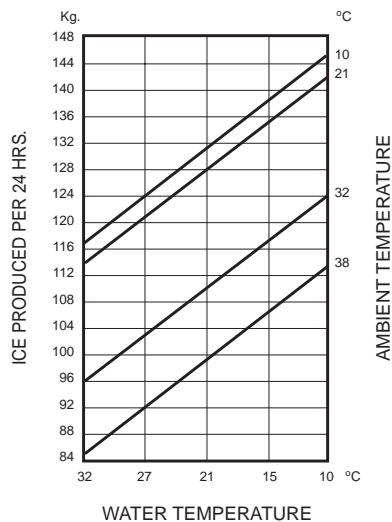

WATER COOLED MODELS

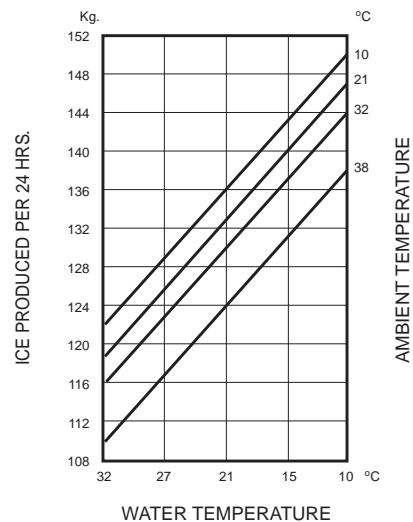

NOTE. The daily ice-making capacity is directly related to the condenser air inlet temperature, water temperature conditions of the condenser air filter and age of the machine. Production charts shown indicate the production of ACM models; ice production of ACL and ACS models is 10% lower. To keep your SCOTSMAN CUBER at peak performance levels, periodic maintenance checks must be carried out as indicated on Maintenance and Cleaning section of this manual.

SPECIFICATIONS

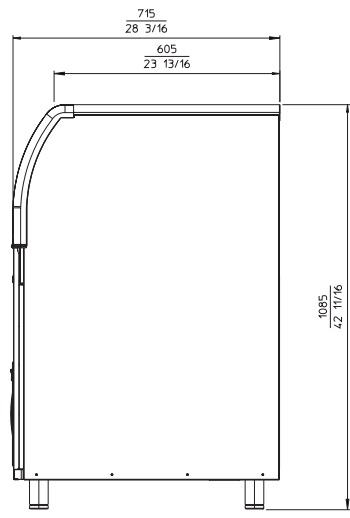
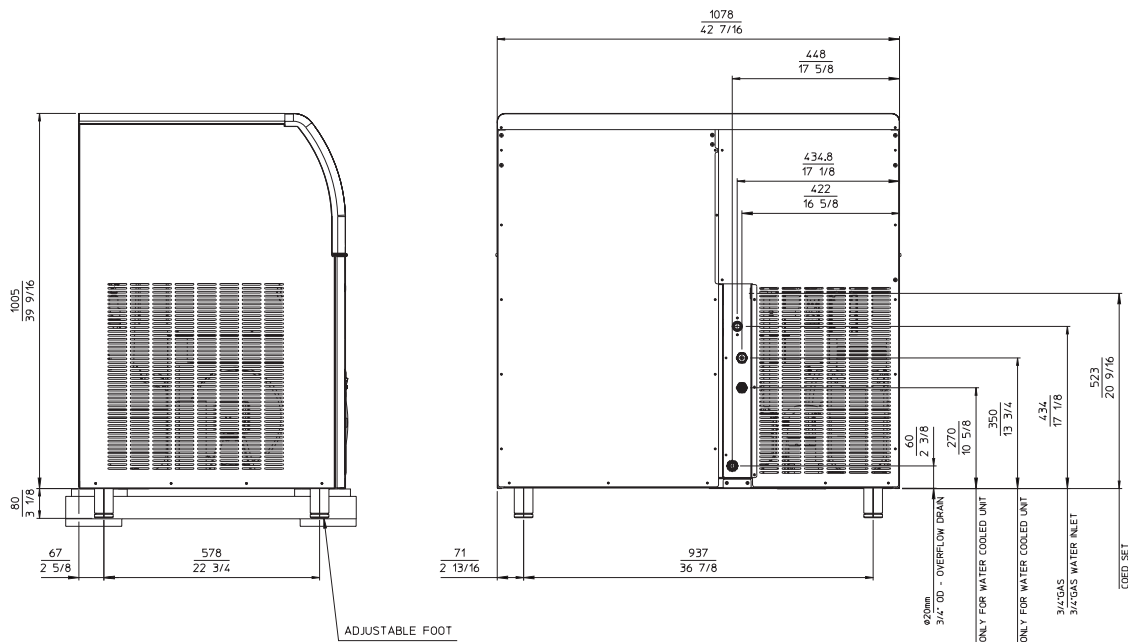

Dimensions:
 HEIGHT (without legs) 1005 mm.
 HEIGHT (with legs) 1085 mm.
 WIDTH 1078 mm.
 DEPTH 715 mm.
 WEIGHT 120 Kgs.

AC/EC 226 - CUBER (R404A / R452A version)
 machine specifications

Model	Cond. unit	Finish	Comp. HP	Bin Capacity	Water req. lt/24 HR	
AC/EC 226 AS AC/EC 226 WS	Air Water	Stainless steel	1	70 Kg.	330 1800*	
Basic electr.	Amps	Start Amps	Watts	Electric power cons. Kwh per 24 Hr	Nr. of wires	Amps fuse
230/50/1	5.2	29	1180	24.2	3 x 1.5 mm ²	16
				19.2		
Cubes per harvest: 72 large / 106 medium / 198 small * At 15°C water temperature						

GENERAL INFORMATION AND INSTALLATION

A. INTRODUCTION

This manual provides the specifications and the step-by-step procedures for the installation, start-up and operation, maintenance and cleaning for the SCOTSMAN AC-EC series icemakers.

These Cubers are quality designed, engineered and manufactured.

Their ice making systems are thoroughly tested providing the utmost in flexibility to fit the needs of a particular user.

These icemakers have been engineered to our own rigid safety and performance standards.

NOTE. *To retain the safety and performance built into this icemaker, it is important that installation and maintenance be conducted in the manner outlined in this manual.*

B. UNPACKING AND INSPECTION

1. Call your authorized SCOTSMAN Distributor or Dealer for proper installation.

2. Visually inspect the exterior of the packing and skid. Any severe damage noted should be reported to the delivering carrier and a concealed damage claim form filled in subject to inspection of the contents with the carrier's representative present.

3. a) Cut and remove the plastic strip securing the carton box to the skid.

b) Cut open the top of the carton and remove the polystyrene protection sheet.

c) Pull out the polystyrene posts from the corners and then remove the carton.

4. Remove the front panel of the unit and inspect for any concealed damage. Notify carrier of your claim for the concealed damage as stated in step 2 above.

5. Check that refrigerant lines do not rub against or touch other lines or surfaces, and that the fan blade moves freely.

6. Check that the compressor fits snugly onto all its mounting pads.

7. Remove all internal support packing and masking tape.

8. Use clean damp cloth to wipe the surfaces inside the storage bin and the outside of the cabinet.

9. See data plate on the rear side of the unit and check that local main voltage corresponds with the voltage specified on it.

CAUTION. *Incorrect voltage supplied to the icemaker will void your parts replacement program.*

10. Remove the manufacturer's registration card from the inside of the User Manual and fill in all parts including: Model and Serial Number taken from the data plate.

Forward the completed self-addressed registration card to Scotsman Ice srl factory.

11. Install the four standard legs supplied in the machine and adjust them to level the unit.

C. LOCATION AND LEVELLING

WARNING. *This Ice Cuber is designed for indoor installation only. Extended periods of operation at temperatures exceeding the following limitations will constitute misuse under the terms of the SCOTSMAN Manufacturer's Limited Warranty resulting in LOSS of warranty coverage.*

1. Position the unit in the selected permanent location.

Criteria for selection of location include:

a) Minimum room temperature 10°C (50°F) and maximum room temperature 40°C (100°F).

b) Water inlet temperatures: minimum 5°C (40°F) and maximum 35°C (90°F).

c) Well ventilated location for air cooled models.

d) Service access: adequate space must be left for all service connections through the rear of the ice maker. A minimum clearance of 15 cm (6") must be left at the sides of the unit for routing cooling air drawn into and exhausted out of the compartment to maintain proper condensing operation of air cooled models.

2. Level the unit in both the left to right and front to rear directions.

D. ELECTRICAL CONNECTIONS

See data plate for current requirements to determine wire size to be used for electrical connections. All SCOTSMAN icemakers require a solid earth wire.

All SCOTSMAN ice machines are supplied from the factory completely pre-wired and require only electrical power connections to the wire cord provided at rear of the unit.

Make sure that the ice machine is connected to its own circuit and individually fused (see data plate for fuse size).

The maximum allowable voltage variation should not exceed -10% and + 10% of the data plate rating.

Low voltage can cause faulty functioning and may be responsible for serious damage to the overload switch and motor windings.

NOTE. *All external wiring should conform to national, state and local standards and regulations.*

Check voltage on the line and the ice maker's data plate before connecting the unit.

E. WATER SUPPLY AND DRAIN CONNECTIONS

GENERAL

When choosing the water supply for the ice maker consideration should be given to:

- Length of run
- Water clarity and purity
- Adequate water supply pressure

Since water is the most important single ingredient in producing ice you cannot emphasize too much the three items listed above.

Low water pressure, below 1 bar may cause malfunction of the ice maker unit.

Water containing excessive minerals will tend to produce cloudy coloured ice cubes, plus scale build-up on parts of the water system.

WATER SUPPLY

Air Cooled Versions

Connect the 3/4" male fitting of the solenoid water inlet valve, using the flexible tube supplied, to the cold water supply line with regular plumbing fitting and a shut-off valve installed in an accessible position between the water supply line and the unit. If water contains a high level of impurities, it is advisable to consider the use an appropriate water filter or conditioner.

Water supply - Water cooled models

The water cooled versions of SCOTSMAN Ice Makers require two separate inlet water supplies, one for the water sprayed for making the ice cubes and the other for the water cooled condenser. Connect the 3/4" GAS male fitting of the water inlet, using the flexible tubing or a 3/8" O.D. copper pipe, to the cold water supply line with regular plumbing fitting and a shut-off valve installed in an accessible position between the water supply line and the unit.

WATER DRAIN

The recommended drain tube is a plastic or flexible tube with 18 mm (3/4") I.D. which runs to an open trapped and vented drain.

WATER DRAIN - WATER COOLED MODELS

Connect the 3/4" male fitting of the condenser water drain, utilizing a second flexible hose, to the open trapped and vented drain.

NOTE. *The water supply and the water drain must be installed to conform with the local code. In some case a licensed plumber and/ or a plumbing permit is required.*

WATER DRAIN - EC version

The water can be pumped out up to 1.5 m rise or

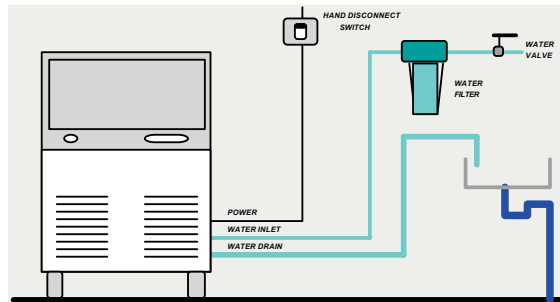

to 30 m on horizontal length.

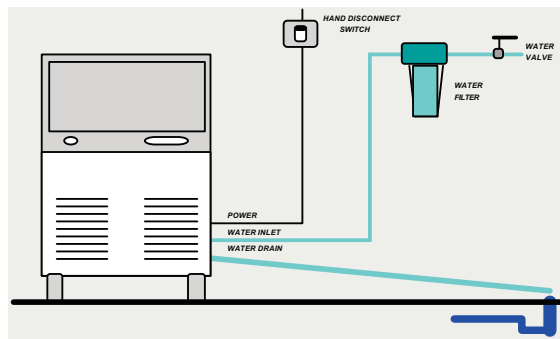

F. FINAL CHECK LIST

- Is the unit in a room where ambient temperatures are within a minimum of 10°C (50°F) even in winter months?
- Is there at least a 15 cm (6") clearance around the unit for proper air circulation?
- Is the unit level? (IMPORTANT)
- Have all the electrical and plumbing connections been made, and is the water supply shut-off valve open?
- Has the voltage been tested and checked against the data plate rating?
- Has the water supply pressure been checked to ensure a water pressure of at least 1 bar (14 psi).
- Check all refrigerant lines and conduit lines to guard against vibrations and possible failure.
- Have the bolts holding the compressor down been checked to ensure that the compressor is snugly fitted onto the mounting pads?
- Have the bin liner and cabinet been wiped clean?

10. Has the owner/user been given the User Manual and been instructed on the importance of periodic maintenance checks?

and serial number against the serial plate and mail the registration card to the factory.

11. Has the Manufacturer's registration card been filled in properly? Check for correct model

12. Has the owner been given the name and the phone number of the authorized SCOTSMAN Service Agency serving him?

G. INSTALLATION PRACTICE

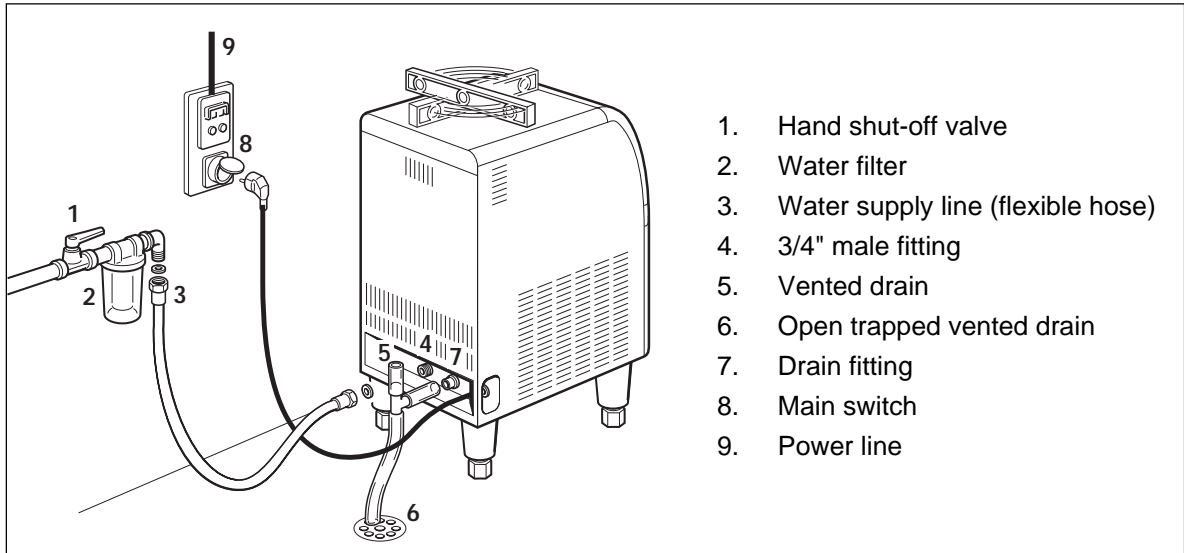

WARNING. This icemaker is not designed for outdoor installation and will not function in ambient temperatures below 10°C (50°F) or above 40°C (100°F). This icemaker will malfunction with water temperatures below 5°C (40°F) or above 35°C (90°F).

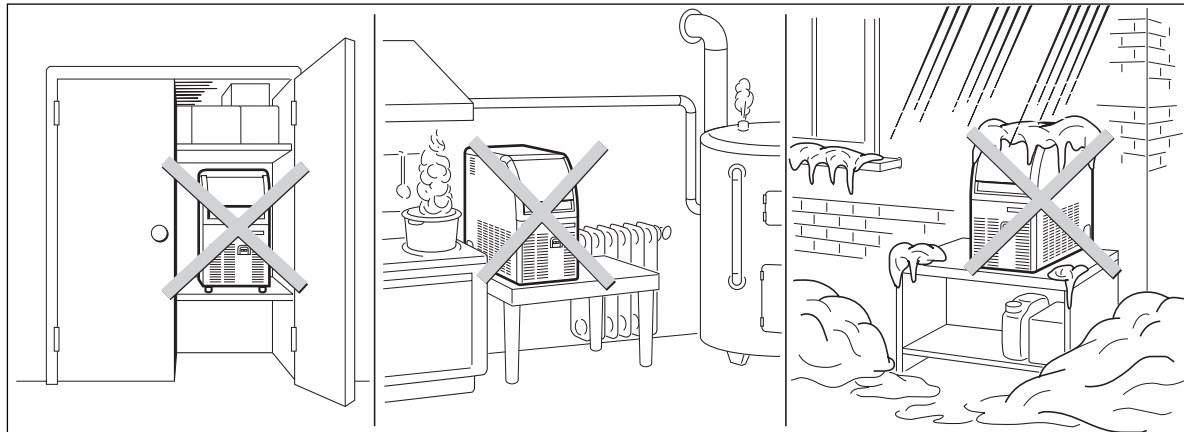

OPERATING INSTRUCTIONS

START UP

After having correctly installed the ice maker and completed the plumbing and electrical connections, perform the following "Start-up" procedure.

- A.** Turn the unit ON by the main switch. Unit will start up in charging cycle mode.

NOTE. Every time the unit returns under power, after having been switched off, the water inlet valve, the hot gas valve and the water drain valve get energized for a period of 5 minutes, thus to admit new water to the machine sump reservoir to fill it up and, eventually, to wash-off any dirt that can have deposited in it during the unit off period (Fig.1).

- B.** During the water filling operation, check to see that the incoming water dribbles, through the evaporator platen dribbler holes, down into the sump reservoir to fill it up and also that the

incoming surplus of water flows out through the overflow pipe into the drain line.

During the water filling phase the components energized are:

THE WATER INLET SOLENOID VALVE

THE HOT GAS SOLENOID VALVE

THE WATER DRAIN SOLENOID VALVE (NOT IN AC/EC 106).

NOTE. If in the 5 minutes length of the water filling phase the machine sump reservoir does not get filled with water up to the rim of the overflow pipe, it is advisable to check:

1. The water pressure of the water supply line that must be at least **1 bar (14 psig)** Minimum (Max 5 bar-70 psig).
2. The filtering device installed in the water line that may reduce the water pressure below the Minimum value of 1 bar (14 psig).
3. Any clogging situation in the water circuit like the inlet water strainer and/or the flow control.

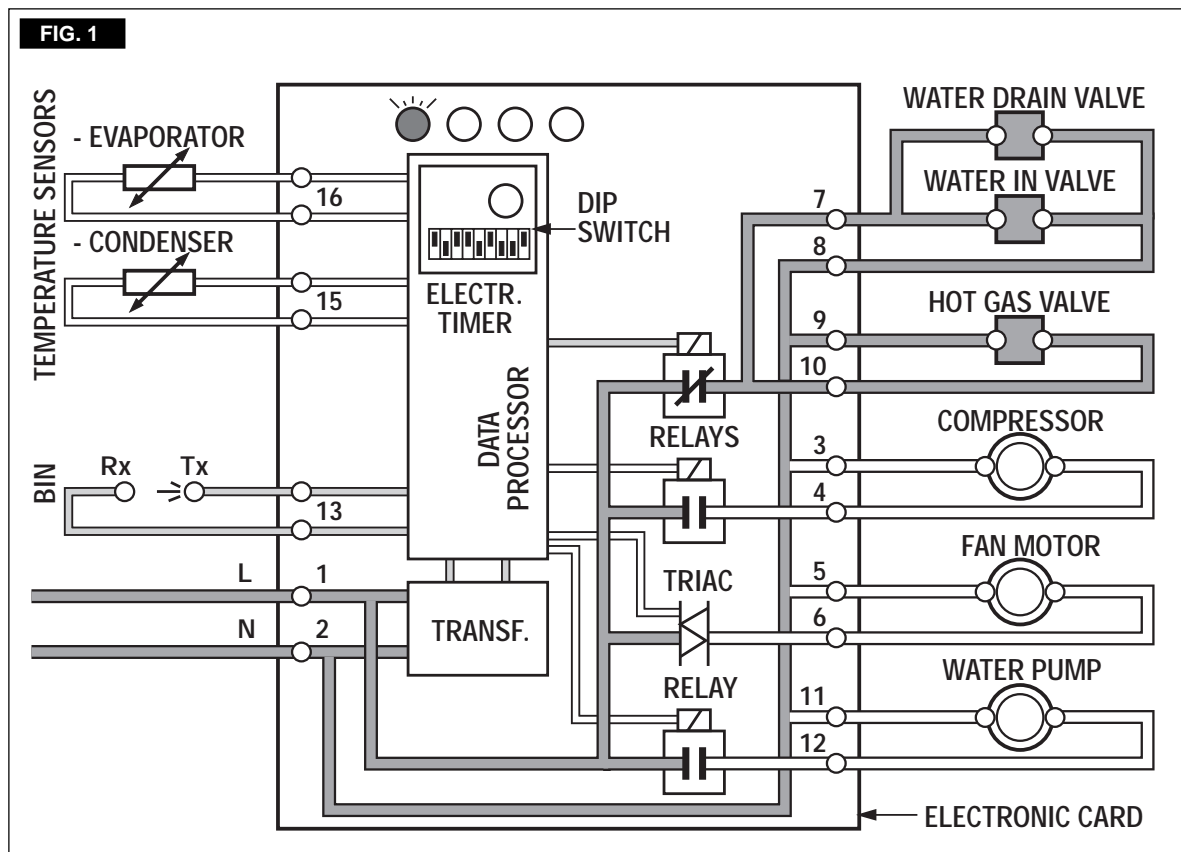

C. At completion of the water filling phase (5 minutes) the unit passes automatically into the freezing cycle with the start up of:

COMPRESSOR

WATER PUMP

FAN MOTOR (in air cooled version) controlled by the condenser temperature sensor located within the condenser fins (Fig.2).

OPERATIONAL CHECKS

D. Install, if required, the refrigerant service gauges on both the high side and low side Scraeder valves to check the compressor head and suction pressures.

NOTE. On air cooled models, the condenser temperature sensor, which is located within the condenser fins, keep the head (condensing) pressure between values as per discharge pressure details at pag. 31.

In case of air condenser filter clogged such to prevent the proper flow of the cooling air or, in case the fan motor is out of operation or shortage of water in the water cooled condenser, the condenser temperature rises and when it reaches 70°C (160°F) - for air cooled version - or 60°C (140°F) - for water cooled version - the condenser temperature sensor shuts-off the ice maker with the consequent light-up of the RED WARNING LED (Fig.3) as well as the Red Alarm Light (ON Steady).



After having diagnosed the reason of the rise of temperature and removed its cause, it is necessary to Switch OFF (wait few seconds) and Switch ON the unit, thus to put the machine in condition to initiate a new freezing cycle.

The machine restarts with the usual 5 minutes water filling phase in order to provide enough water into the sump tank.

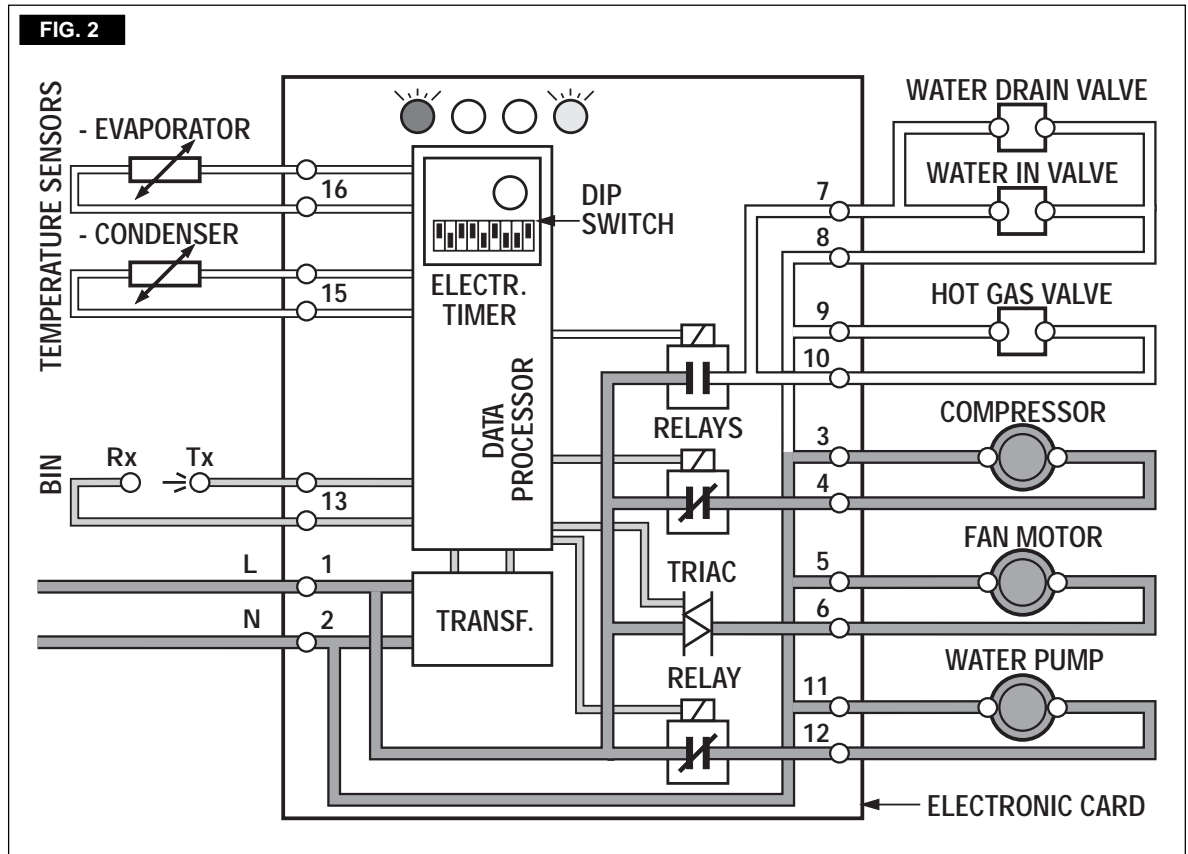

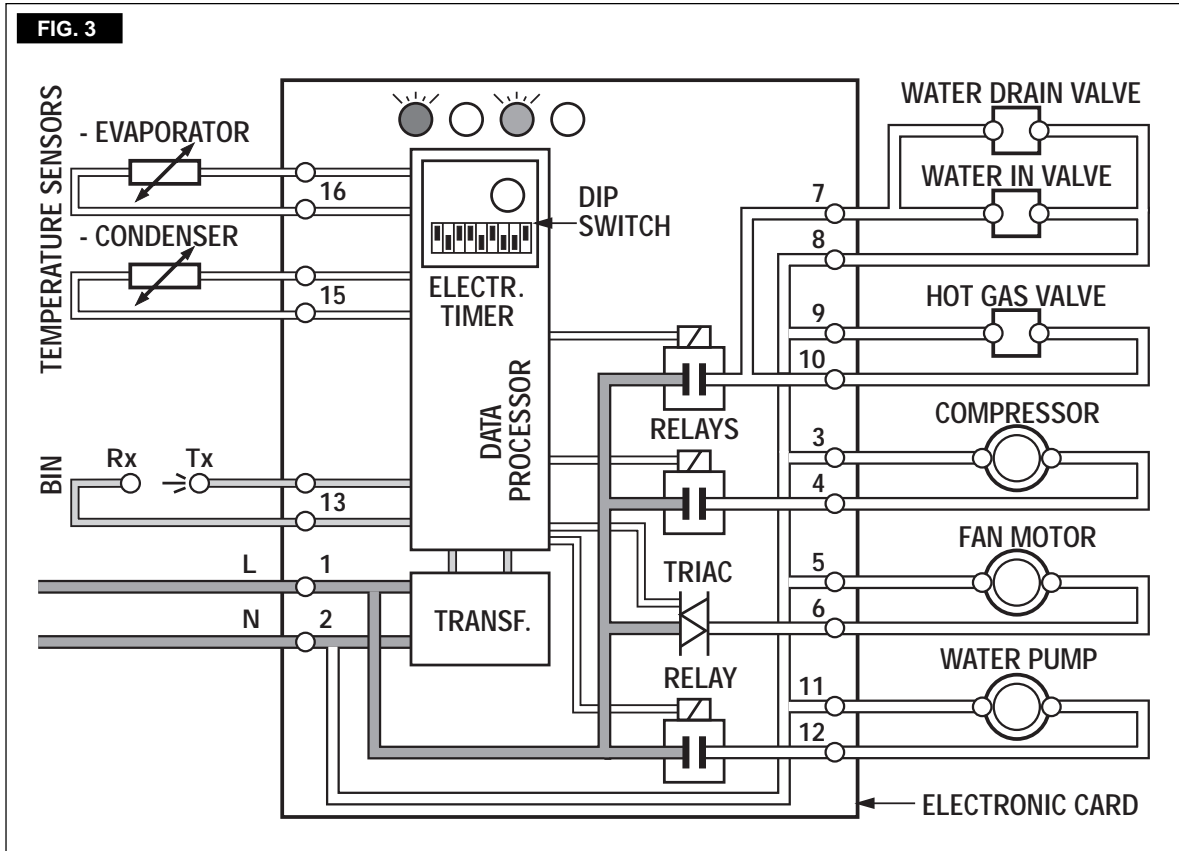

E. Check to see through the ice discharge opening that the spray system is correctly seated and that the water jets uniformly reach the

interior of the inverted mold cups; also make sure that the plastic curtain is hanging freely and there is not excessive water spilling through it.

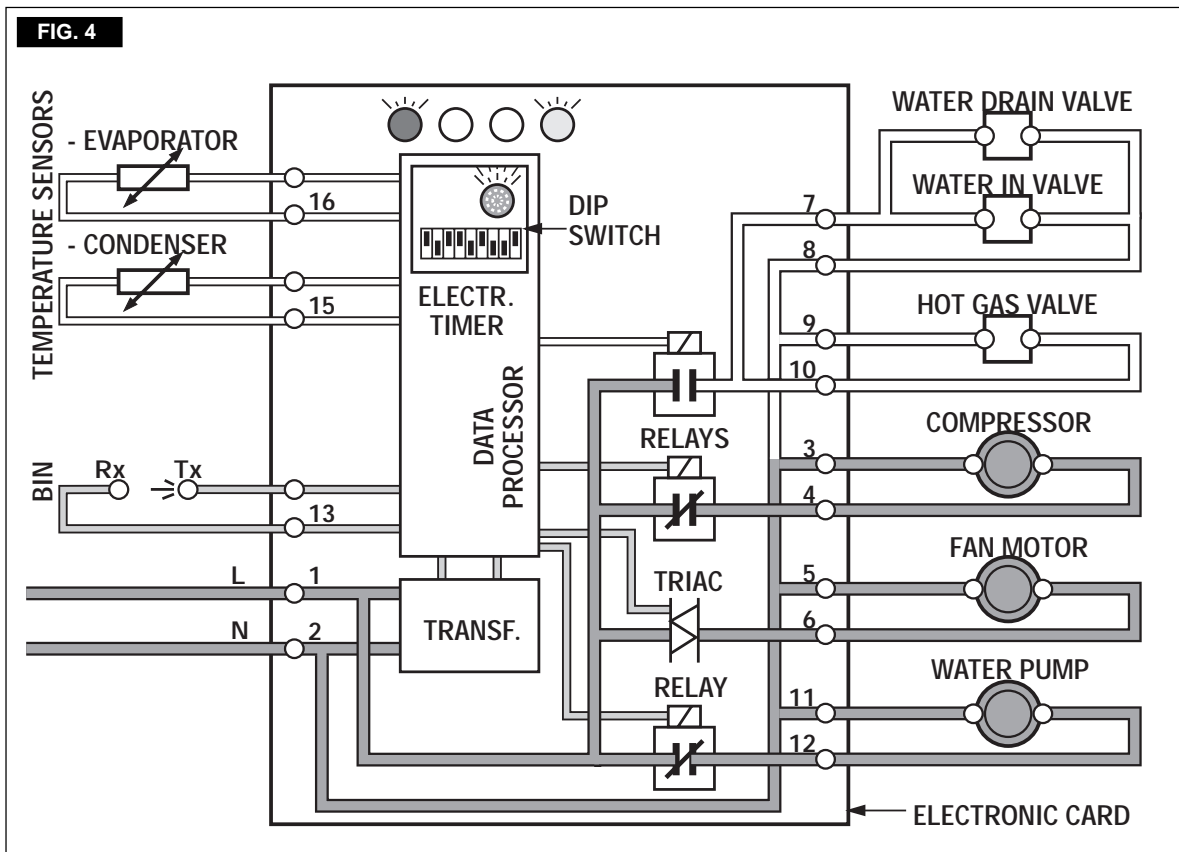

F. The ice making process takes place thereby, with the water sprayed into the molds that gets gradually refrigerated by the heat exchange with the refrigerant flowing into the evaporator serpentine. During the freezing process, the evaporator temperature falls to 0°C (Red Led blinking as per Fig. 4) and then to -15°C (Red Led ON steady as per Fig. 4a). When it reaches -15°C the evaporator temperature sensor supplies a low voltage power signal to the electronic control device (P.C.BOARD) in order to activate an electronic timer. This one takes over the control of the freezing cycle up to the complete formation of the ice cubes.

NOTE. The length of the entire freezing cycle is governed by the evaporator temperature sensor which has its probe placed in contact with the evaporator serpentine (Non adjustable) in combination with the electronic timer (Adjustable) incorporated in the P.C.BOARD. The timer adjustment is factory set in consideration of the ice maker type, cooling version and ice cube size (Small, Medium, Large). It is possible, however, to modify the timed length of the freezing cycle, by changing the **DIP SWITCH** keys setting. In Table B of PRINCIPLE OF OPERATION are shown the various time extensions of the freezing cycle second phase, in relation with the different DIP SWITCH keys setting.

G. After about 17+20 minutes from the beginning of the freezing cycle, in an hypothetic ambient temperature of 21°C, the defrost cycle takes place with the hot gas, the water inlet

and the water drain valves simultaneously activated (Fig. 5).

The electrical components in operation on models are:

- COMPRESSOR**
- WATER INLET VALVE**
- HOT GAS VALVE**
- WATER DRAIN VALVE** (not in AC/EC 106)
- WATER PUMP**

on the first 15 seconds on models only AC/EC 126-176 and on the first 30 seconds on AC/EC 206-226.

NOTE. The length of the defrost cycle is automatically determined by the micro-processor of the P.C. BOARD in relation of the time necessary for the unit to reduce the evaporator temperature from 0°C (32°F) small Red LED blinking to -15°C (5°F) small Red LED ON steady - TIME T2. It is possible to extend the length of the defrost cycle by changing the setting of DIP SWITCH 7 and 8 as shown on table at page 37.

H. Check, during the defrost cycle, that the incoming water flows correctly into the sump reservoir in order to refill it and that the surplus overflows through the overflow drain tube.

I. Check the texture of ice cubes just released. They have to be in the right shape with a small depression of about 5-6 mm in their crown. If not, wait for the completion of the second cycle before performing any adjustment.

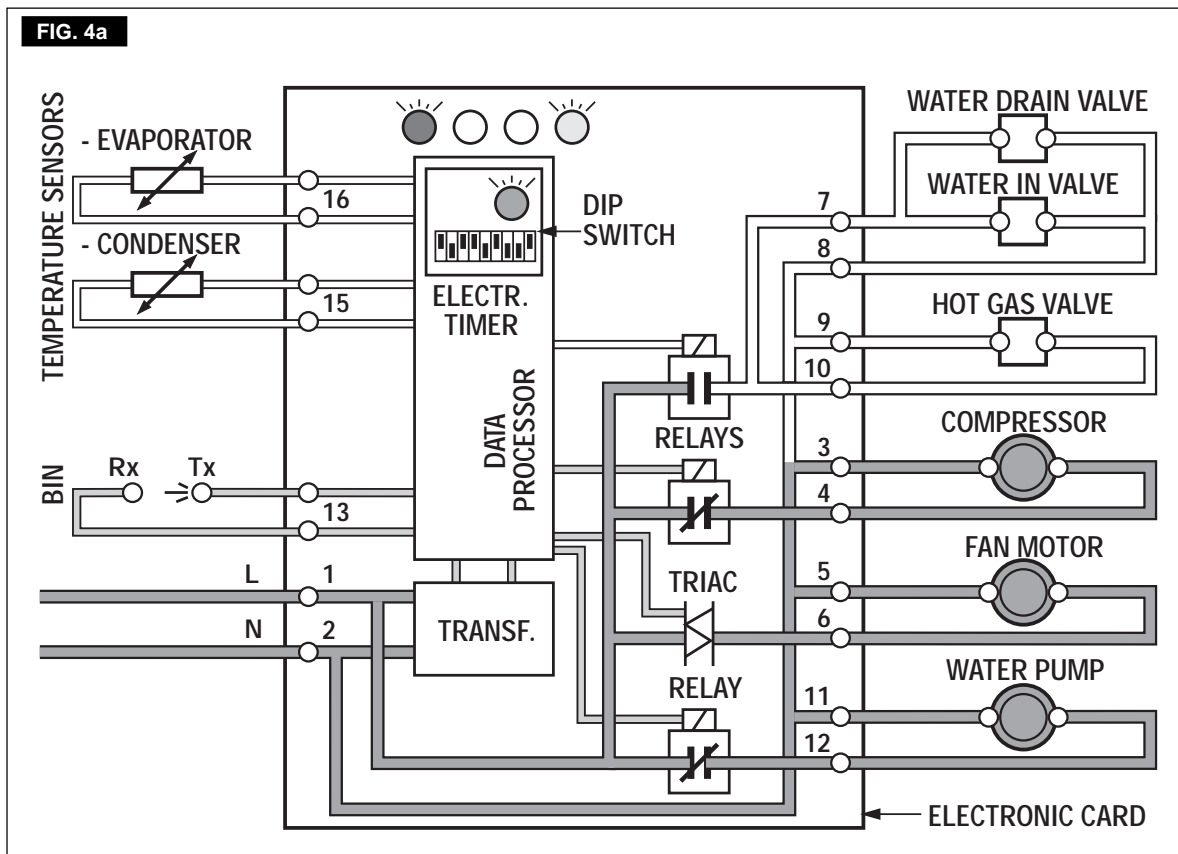

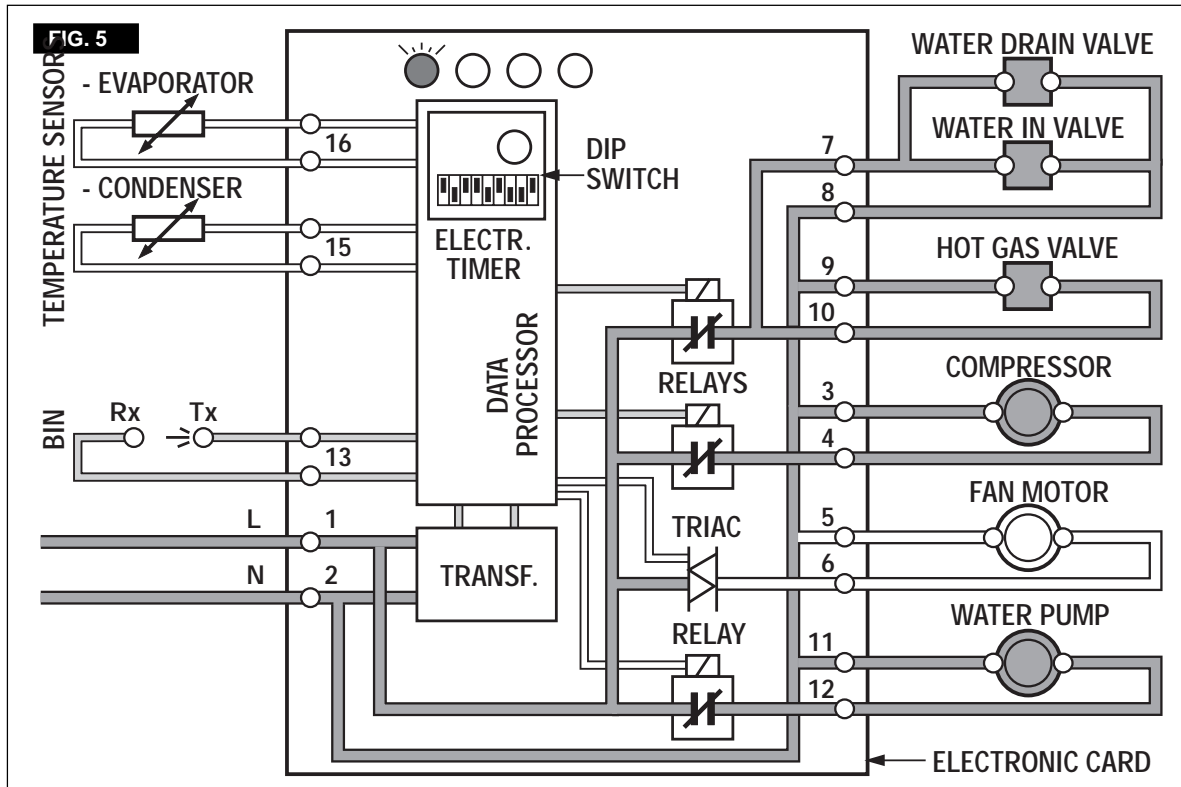

If the ice cubes are shallow and cloudy, it is possible that the ice maker runs short of water during the freezing cycle second phase or, the quality of the supplied water requires the use of an appropriate water filter or conditioner. Only EC version as soon as the water into the Sealed Water Reservoir reaches the maximum level, the two metal pins close the electrical contact through the water, transmitting a low voltage current to the PC Board.

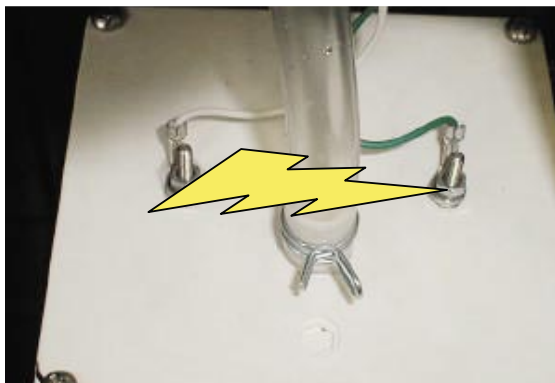

The PC Board activates the Water Drain Pump for 8 seconds pumping out most of the water contained into the Sealed Water Reservoir.

J. Upon the model, these icemakers range shall operate either by **IR control** device which operates by sensing eyes or **Thermal sensor**. Thermal sensor can detecting both the low temperature of the ice also the mass of the ice near its sensing bulb.

For testing devices:

- **Storage bin thermal sensor**; place some ice cubes in contact with the bulb, icemaker turn OFF at the end of harvest cycle. Remove ice from the bulb, ice maker restart from new freezing cycle.

- **Optical level sensor (IR)**; place some ice cubes between IR optical sensing eyes. The Bin Full YELLOW LED starts blinking (Fig. 6), and when defrost cycle is over, the unit stops with the simultaneous glowing of the same LED to monitor the BIN FULL situation (Fig. 6a).
- Whenever necessary, pcb can be "calibrated" to assure the best communication between the same and ice level device just by turn the Main switch OFF an ON again.

Take the hand out from the ice level control sensors to allow the resumption of the light beam. After approximately 6 seconds the ice maker resume its operation with the immediate glowing of the **FIRST YELLOW LED** indicating **UNIT IN OPERATION** and the extinguishing of the "BIN FULL" YELLOW LED.

NOTE. The **ICE LEVEL CONTROL (INFRARED SYSTEM)** is independent of the temperature however, the reliability of its detection can be affected by external light radiations or by any sort of dirt and scale sediment which may deposit directly on the light source and on the receiver. To prevent any possible ice maker malfunction, due to negative affection of the light detector, it is advisable to locate the unit where it is **not reached by any direct light beam** or light radiation, also it is recommended to keep the bin door constantly closed and to follow the instructions for the **periodical cleaning of the light sensor elements** as detailed in the **MAINTENANCE AND CLEANING PROCEDURES**.

This ice maker is equipped by an I/R self-calibration PC Board every time ice maker is turned OFF and ON by the main switch.

K. Remove, if fitted, the refrigerant service gauges and re-fit the unit service panels previously removed.

L. Instruct the owner/user on the general operation of the ice machine and about the cleaning and care it requires.

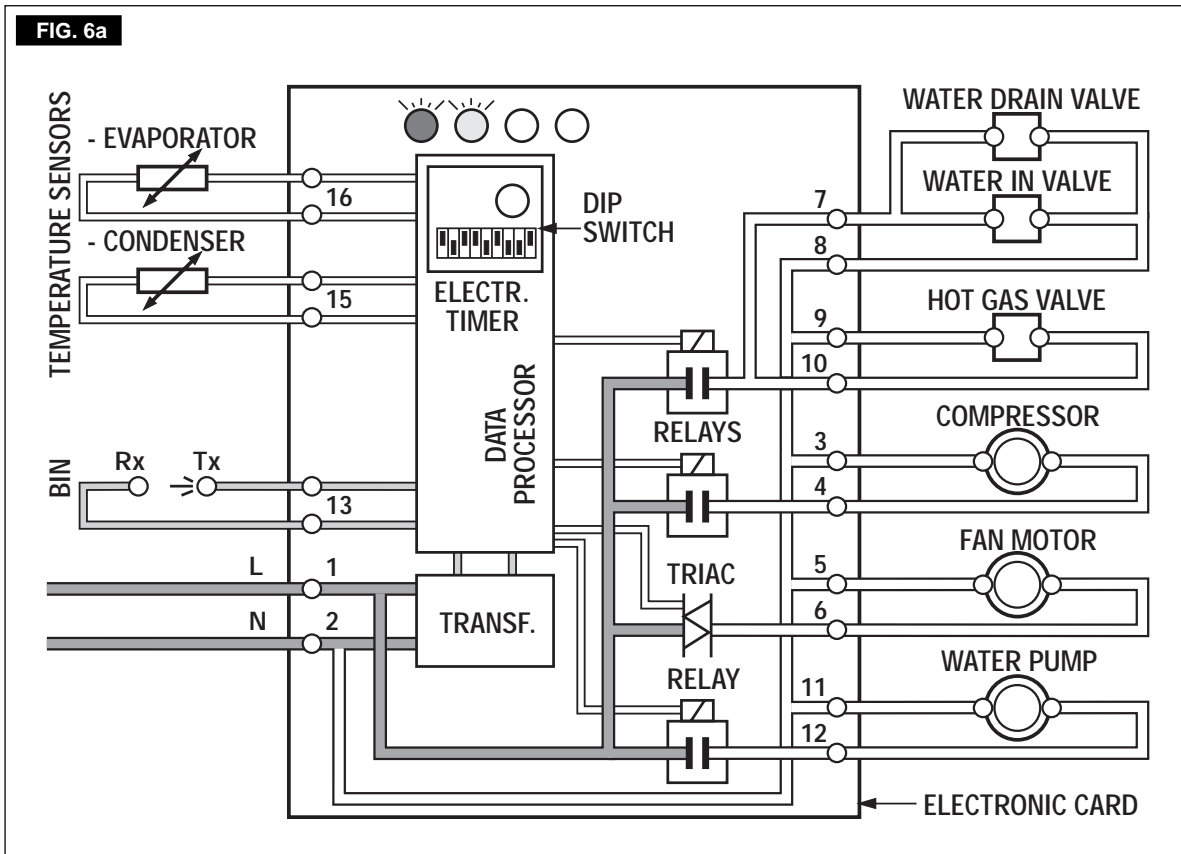
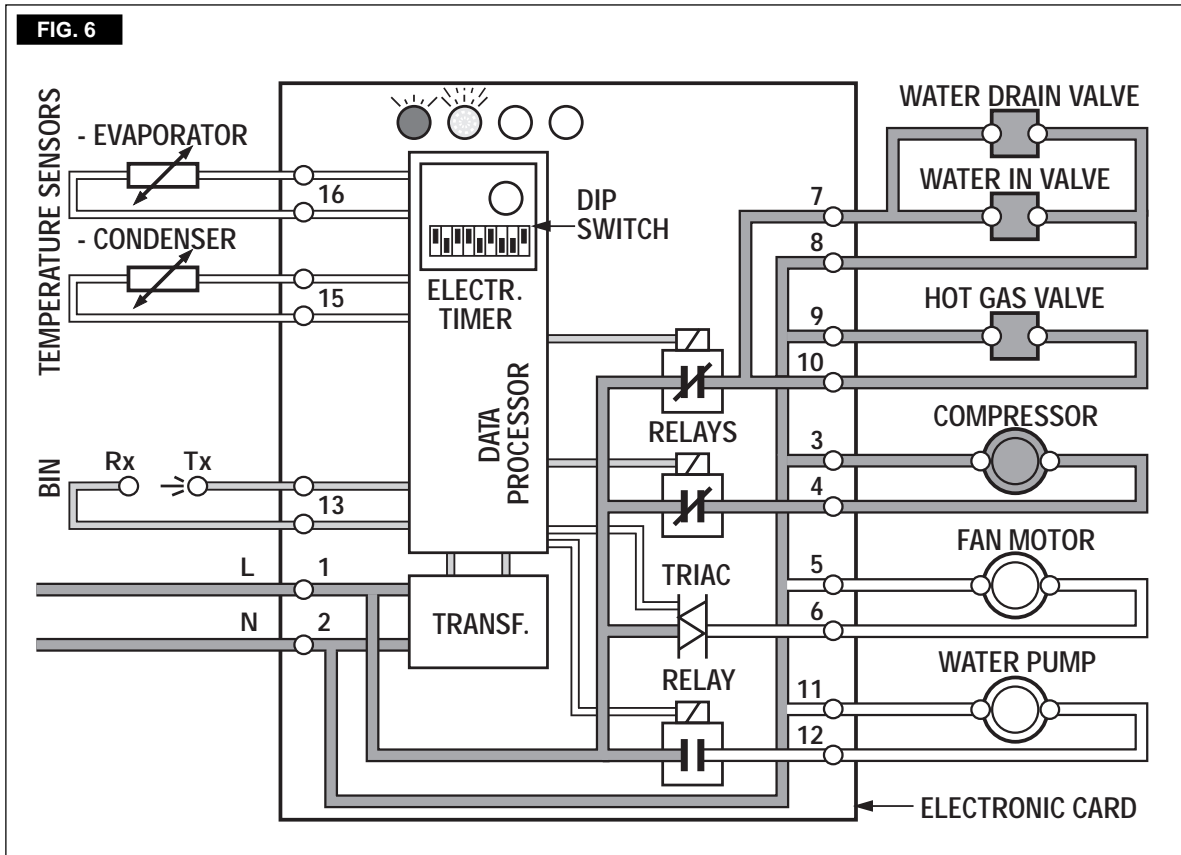

PRINCIPLE OF OPERATION

How it works

In the **SCOTSMAN** cube ice makers the water used to make the ice is kept constantly in circulation by an electric water pump which primes it to the spray system nozzles from where it is diverted into the inverted mold cups of the evaporator. A small quantity of the sprayed water freezes into ice; the rest of it cascades by gravity into the sump assembly below for recirculation.

FREEZING CYCLE (Fig. A - B - C - D)

The hot gas refrigerant discharged out from the compressor reaches the condenser where, being cooled down, condenses into liquid.

Flowing into the liquid line it passes through the drier filter, then it goes all the way through the capillary tube where, due to the heat exchanging action, it loses some of its heat content so that its pressure and temperature are lowered as well. Next the refrigerant enters into the evaporator serpentine (which has a larger I.D. than the capillary) and starts to boil off; this reaction is emphasized by the heat transferred by the sprayed water. The refrigerant then increases in volume and changes entirely into vapor.

The vapor refrigerant then passes through the suction accumulator (used to prevent that any small amount of liquid refrigerant may reach the compressor) and through the suction line. In both the accumulator and the suction line it exchanges heat with the refrigerant flowing into the capillary tube (warmer), before to be sucked in the compressor and to be recirculated as hot compressed refrigerant gas.

The freezing cycle is controlled by the evaporator

temperature sensor (which has its probe in contact with the evaporator serpentine) that determines the length of its first portion of the cycle.

When the temperature of the evaporator serpentine drops to a pre-set value (small Red LED ON steady) the evaporator sensor probe changes its electrical resistance allowing a low voltage current (15 volts) to flow to the P.C. BOARD which in turn activates an electronic timer. The timer, which is built-in the P.C. BOARD, takes over from the evaporator temperature sensor, the control of the freezing cycle up to its completion.

NOTE. *The change of the electric potential of the evaporator sensor with the consequent activation of the timer (Time mode) is signalled by the glowing-up of the RED LED located in the front of the P.C. BOARD.*

ATTENTION. In case, after 15 minutes from the beginning of the freezing cycle, the temperature of the evaporator sensor probe is higher than 0° C (32°F) - small Red LED still OFF - (shortage of refrigerant, inoperative hot gas valve, etc.) the P.C. BOARD switch OFF immediately the unit with the simultaneous blinking of the WARNING RED LED.

The length of this timed portion of the freezing cycle is pre-fixed and related to the setting of the first four DIP SWITCH keys. The DIP SWITCH keys setting is made in consideration of the type of condenser used and size of ice cubes.

TAB. A DIP SWITCH FACTORY SETTING COMBINATIONS (PER MODEL AND VERSION)										
DIP SWITCH	FREEZING CYCLE				DEFROST CYCLE		DEFROST CYCLE ADD. TIME		15/30"	AIR/WATER
	1	2	3	4	5	6	7	8	9	10
A/ECM 106 A - R134A	ON	ON	OFF	ON	ON	OFF	ON	ON	OFF	ON
A/ECM 106 W - R134A	ON	ON	OFF	ON	ON	OFF	ON	ON	OFF	OFF
A/ECL 106 A - R134A	OFF	OFF	OFF	ON	OFF	ON	ON	ON	OFF	ON
A/ECL 106 W - R134A	OFF	OFF	OFF	ON	OFF	ON	ON	ON	OFF	OFF
A/ECM 126 A - R404A	ON	ON	OFF	ON	ON	OFF	ON	ON	OFF	ON
A/ECM 126 W - R404A	ON	ON	OFF	ON	OFF	ON	ON	ON	OFF	OFF
A/ECM 126 a - R134A	OFF	OFF	ON	ON	ON	ON	ON	ON	OFF	ON
A/ECM 126 W - R134A	OFF	OFF	ON	ON	OFF	ON	OFF	ON	OFF	OFF
A/ECM 176 A - R404A	ON	ON	OFF	ON	OFF	ON	ON	ON	OFF	ON
A/ECM 176 W - R404A	ON	ON	OFF	ON	OFF	ON	OFF	ON	OFF	OFF
A/ECM 176 A - R134A	OFF	OFF	ON	ON	ON	ON	ON	ON	OFF	ON
A/ECM 176 W - R134A	OFF	OFF	ON	ON	OFF	ON	OFF	ON	OFF	OFF
A/ECS 206-226 A - R404A	ON	OFF	ON	ON	OFF	ON	ON	ON	ON	ON
A/ECM 206-226 A - R404A	ON	ON	OFF	ON	OFF	ON	ON	ON	ON	ON
A/ECM 206-226 W - R404A	ON	ON	OFF	ON	OFF	ON	ON	ON	ON	OFF
A/ECL 206 A - R404A	OFF	OFF	OFF	ON	OFF	ON	ON	ON	ON	OFF
A/ECL 206 W - R404A	OFF	OFF	OFF	ON	OFF	ON	ON	ON	ON	OFF
A/ECM 206 A - R452A	OFF	OFF	ON	ON	ON	ON	ON	ON	ON	ON
A/ECM 206 W - R452A	OFF	OFF	ON	ON	ON	ON	OFF	ON	ON	OFF
A/ECM 226 A - R452A	ON	ON	OFF	ON	OFF	ON	ON	ON	ON	ON
A/ECM 226 W - R452A	OFF	OFF	ON	ON	OFF	ON	OFF	ON	ON	OFF

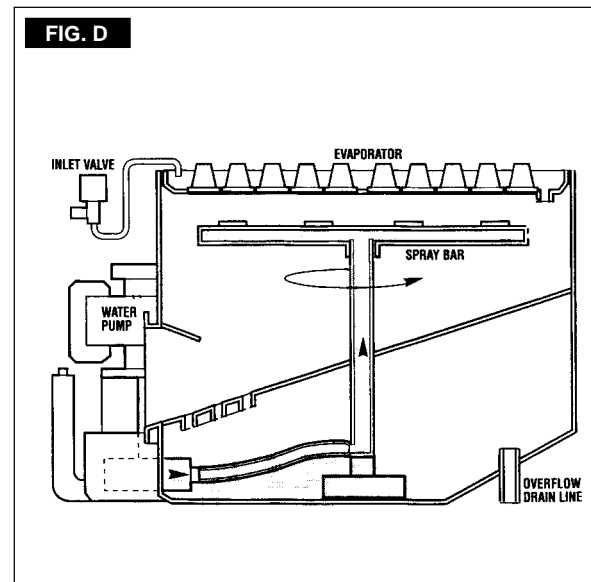
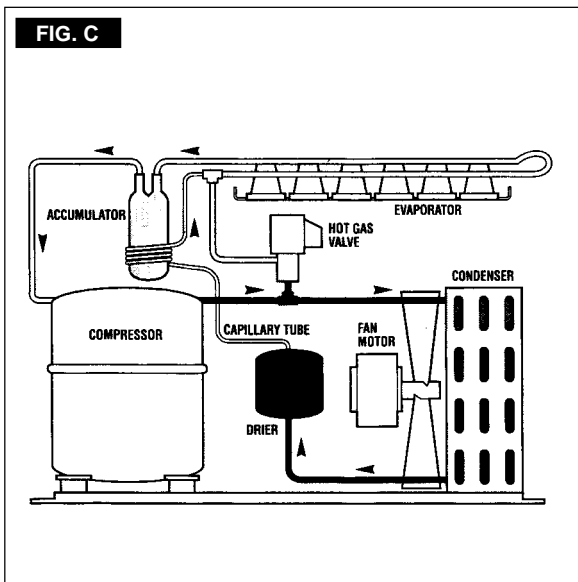
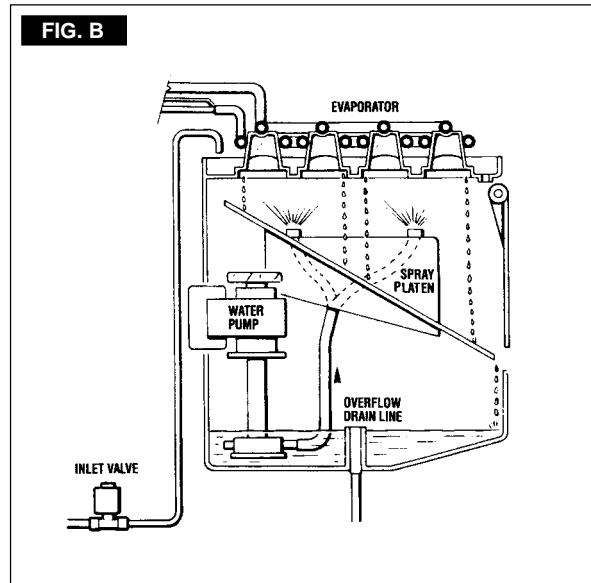
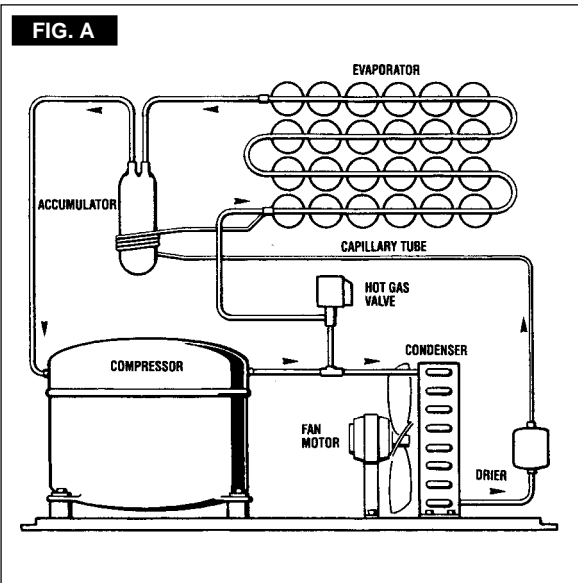

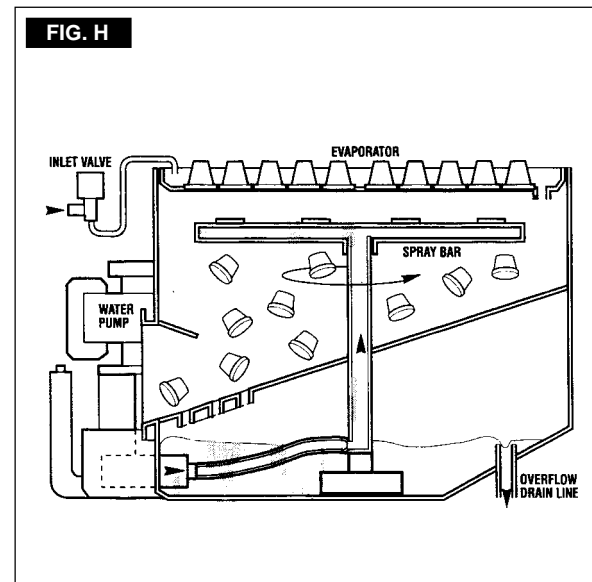
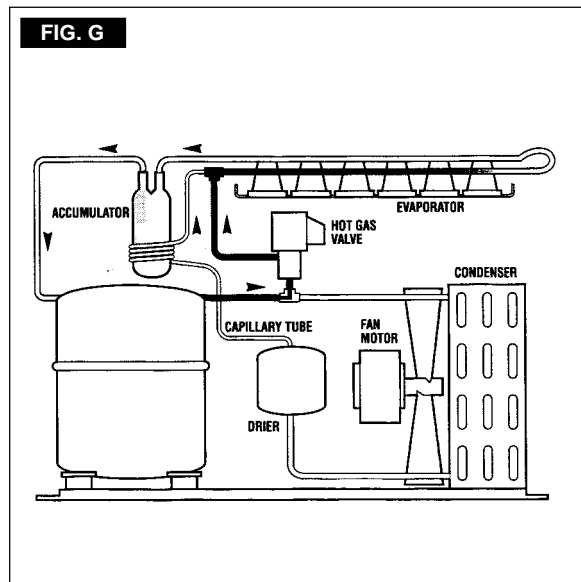
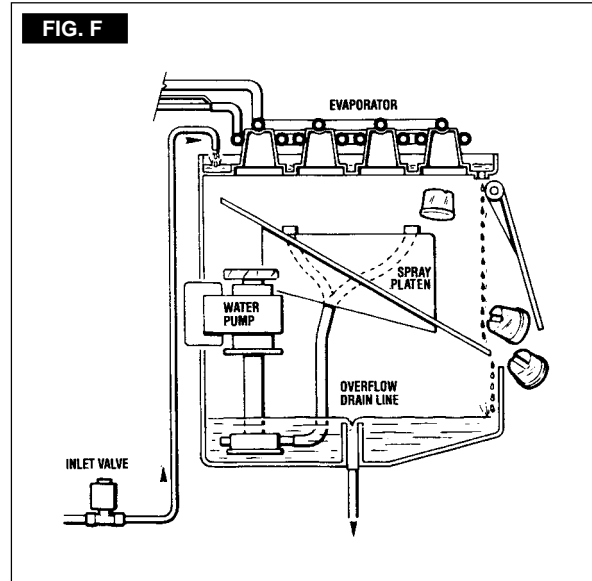
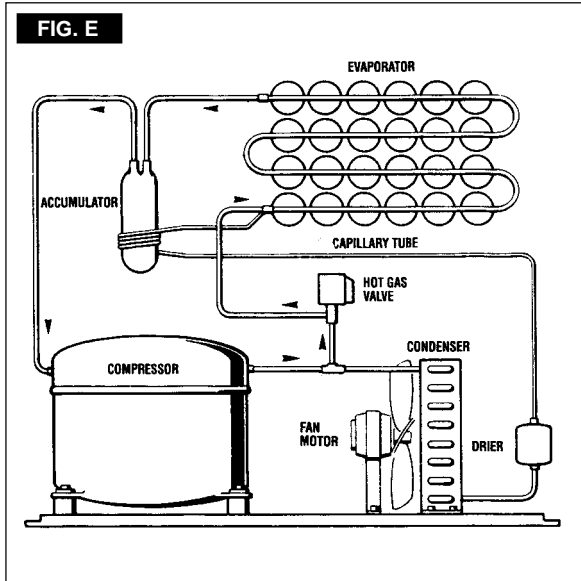

In Table B are indicated the various lengths of the timed portion of freezing cycle in relation to the different combinations of the DIP SWITCH KEYS. In Table A are illustrated the DIP SWITCH keys combinations for the different models and versions as they are set in the factory. The electrical components in operation during the freezing cycle are:

COMPRESSOR

FAN MOTOR (in air cooled version)

WATER PUMP

and during the second phase of freezing cycle (Time mode) they are joined by the

ELECTRONIC TIMER

The refrigerant head pressure, in the course of the freezing cycle, values change upon refrigerant type and according to the model in the air cooled version, being controlled by the temperature sensor probe located within the condenser fins. On the air cooled version, the condenser temperature sensor, when senses a rising of the condenser temperature beyond the pre-fixed limit, changes its electrical resistance and transmits a low voltage power flow to the Micro Processor of P.C. BOARD which in turn energizes, through a **TRIAC**, the **FAN MOTOR**.

When the opposite situation occurs, i.e. the condenser temperature gets below the pre-fixed limit, the temperature sensor changes again its electrical resistance reducing therefore the current flow to the P.C. BOARD to cause the fan motor temporary cut-off.

NOTE. In case the condenser temperature probe senses that the condenser temperature has risen to 70°C (160°F) - on air cooled versions - or 60°C (140°F) - on water cooled versions - for one of the following reasons:
CLOGGED CONDENSER (Air cooled version)
INSUFFICIENT FLOW OF COOLING WATER (Water cooled version)
FAN MOTOR OUT OF OPERATION (Air cooled version)
AMBIENT TEMPERATURE HIGHER THEN 40°C (100°F)
*it causes the total and immediate SHUT-OFF of the machine in order to prevent the unit from operating in abnormal and dangerous conditions. When the ice maker stops on account of this protective device, there is a simultaneous glowing of the **RED LED** and **RED LIGHT (STEADY)**, warning the user of the **Hi Temperature** situation. After having eliminated the source of the condenser hi-temperature, to restart the machine it is necessary to switch OFF (wait few seconds) and switch ON again the unit. The ice machine resumes its normal operation by going through the 5 minutes water filling phase.*

At the start of the freezing cycle the refrigerant suction or lo-pressure declines gradually according to the ice maker model and used refrigerant with the growing of the ice thickness

with the cubes fully formed in the cup molds. The total length of the freezing cycle ranges from 20 to 25 minutes.

DEFROST OR HARVEST CYCLE (Fig. E-F-G-H)

As the electronic timer has carried the system throughout the second phase of freezing cycle, the defrost cycle starts.

ATTENTION. In case the unit is able to reach 0°C (32°F) evaporating temperature within 15 minutes, but after 45 minutes from the beginning of the freezing cycle it has not yet reached the evaporator temperature of -15°C (5°F) the machine goes straight into the defrost cycle omitting the timed portion of the freezing cycle relied to the setting of the first four DIP SWITCHES.

NOTE. The length of the defrost cycle is related to the length of the second phase of freezing cycle T2. (Time to drop the evaporating temperature from 0°C (32°F) - small Red LED blinking - to -15°C (5°F) small Red LED ON steady.
 It is possible to extend the length of the defrost cycle by changing the setting of DIP SWITCH 7 and 8 as shown on table at page 37.

The electrical components in operation during this phase are:

- COMPRESSOR**
- WATER INLET VALVE**
- HOT GAS VALVE**
- WATER DRAIN VALVE** (not on AC/EC 106)

and the

WATER PUMP

the first 15 seconds on AC/EC 126-176 and 30 seconds on AC/EC 206-226.

The incoming water, passing through the water inlet valve and the flow control, runs over the evaporator platen and then flows by gravity through the dribbler holes down into the sump/reservoir. (Fig. F - H)

The water filling the sump/reservoir forces part of the surplus water from the previous freezing cycle to go out to the waste through the overflow pipe. This overflow limits the level of the sump water which will be used to produce the next batch of ice cubes. Meanwhile, the refrigerant as hot gas, discharged from the compressor, flows through the hot gas valve directly into the evaporator serpentine by-passing the condenser. The hot gas circulating into the serpentine of the evaporator warms up the copper molds causing the defrost of the ice cubes. The ice cubes, released from the cups, drop by gravity onto a slanted cube chute, then through a curtained opening they fall into the storage bin. At the end of the defrost cycle, the hot gas valve, the water inlet valve and the water drain valve close and the machine starts again a new freezing cycle.

OPERATION - CONTROL SEQUENCE

At the start of freezing cycle the evaporator temperature sensor controls the length of the first part of the freezing cycle.

As it reaches a predetermined temperature it supplies a low voltage current to the P.C. BOARD in order to activate the electronic timer which takes over the control of the freezing cycle for a pre-fixed time according to the DIP SWITCH keys setting (see Tab. B).

NOTE. *The evaporator temperature sensor, factory pre-set, is the same for all the models and is not adjustable in the field.*

Once completed the timed portion of the freezing cycle the system goes automatically into the defrost cycle which has also a pre-fixed length. At completion of the defrost cycle the P.C. BOARD command the unit to start again a new freezing cycle.

OPERATION - ELECTRICAL SEQUENCE

The following charts illustrate which switches and which components are ON or OFF during a particular phase of the icemaking cycle. Refer to the wiring diagram for a reference.

BEGINNING FREEZE

Electrical components (Loads)	ON	OFF
Compressor	●	
Fan Motor (Air cooled only) and TRIAC	●	
Hot Gas Valve		●
Water Inlet Valve		●
Water Drain Valve (not on AC/EC 106) ...		●
P.C.Board Relay 1 Coil		●
P.C.Board Relay 2 & 3 Coil	●	
Water Pump	●	
P.C.B. Timer		●
Electronic Controls & Sensors	ON	OFF
Evaporator Sensor		●
Condenser Sensor	●	
Ice Level Control	●	

TIMED FREEZE

Electrical components (Loads)	ON	OFF
Compressor	●	
Fan Motor (Air cooled only) and TRIAC	●	●
Hot Gas Valve		●
Water Inlet Valve		●
Water Drain Valve (not on AC/EC 106) ...		●
P.C.Board Relay 1 Coil		●
P.C.Board Relay 2 & 3 Coil	●	
Water Pump	●	
P.C.B. Timer	●	
Electronic Controls & Sensors	ON	OFF
Evaporator Sensor	●	
Condenser Sensor	●	●
Ice Level Control	●	

HARVEST (Drain portion - first 15 sec.)

Electrical components (Loads)	ON	OFF
Compressor	●	
Fan Motor (Air cooled only) and TRIAC		●
Hot Gas Valve	●	
Water Inlet Valve	●	
Water Drain valve (not on AC/EC 106) ...	●	
P.C.Board Relay 1 & 2 Coil	●	
P.C.Board Relay 3 Coil	●	
Water Pump	●	
P.C.B. Timer	●	
Electronic Controls & Sensors	ON	OFF
Evaporator Sensor		●
Condenser Sensor		●
Ice Level Control	●	

HARVEST (Water filling portion)

Electrical components (Loads)	ON	OFF
Compressor	●	
Fan Motor (Air cooled only) and TRIAC		●
Hot Gas Valve	●	
Water Inlet Valve	●	
Water Drain valve (not on AC/EC 106) ...	●	
P.C.Board Relay 1 & 2 Coil	●	
P.C.Board Relay 3 Coil		●
Water Pump		●
P.C. Board Timer	●	
Electronic Controls & Sensors	ON	OFF
Evaporator Sensor		●
Condenser Sensor		●
Ice Level Control	●	

OPERATING CHARACTERISTICS**REFRIGERANT CHARGES**

MODEL	REFRIGERANT TYPE		
	R134A	R404A	R452A
AC/EC 106 A	320 gr	***	***
AC/EC 106 W	250 gr	***	***
AC/EC 126 A	430 gr	340 gr	***
AC/EC 126 W	370 gr	330 gr	***
AC/EC 176 A	350 gr	340 gr	***
AC/EC 176 W	400 gr	420 gr	***
AC/EC 206 A	***	490 gr	780 gr
AC/EC 206 W	***	400 gr	460 gr
AC/EC 226 A	***	620 gr	620 gr
AC/EC 226 W	***	500 gr	550 gr

MODEL	REFRIG. TYPE	OPERATING PRESSURES	
		21°C temp. amb./15°C temp. water	
		Discharge (bar)	Suction (bar)
AC/EC 106 A	R134A	9,5 ÷ 8,5	0 ÷ 0,1
AC/EC 106 W	R134A	10,5 ÷ 9,5	0 ÷ 0,1
AC/EC 126 A	R134A	7 ÷ 9	0 ÷ 0,1
AC/EC 126 W	R134A	9,5	0 ÷ 0,1
AC/EC 126 A	R404A	15 ÷ 17	1,7
AC/EC 126 W	R404A	17	1,7
AC/EC 176 A	R134A	6 ÷ 8	0 ÷ 0,2
AC/EC 176 W	R134A	9	0 ÷ 0,2
AC/EC 176 A	R404A	15 ÷ 17	1,7
AC/EC 176 W	R404A	17	1,7
AC/EC 206 A	R404A	15 ÷ 17	1,7
AC/EC 206 W	R404A	17	1,7
AC/EC 206 A	R452A	16,5 ÷ 20,5	1,7
AC/EC 206 W	R452A	19	2,2
AC/EC 226 A	R404A	15 ÷ 17	1,7
AC/EC 226 W	R404A	17	1,7
AC/EC 226 A	R452A	15 ÷ 17	1,2
AC/EC 226 W	R452A	17	1,2

REFRIGERANT METERING DEVICE:
capillary tube

PWD SYSTEM (EC version only)

COMPONENTS

The components of the Pump Out Water Drain System are

- Sealed water tank
- PC Board & Sensor
- Sealed Water Pump
- Check Valve

OPERATION

All water coming from the overflow, and from the melted ice is collected inside the Sealed Water Reservoir.

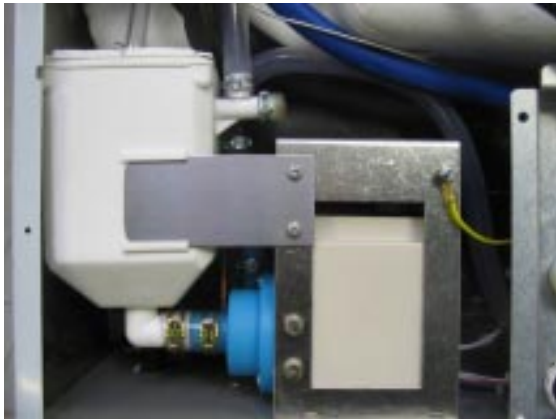

As soon as the water into the Sealed Water Reservoir reaches the maximum level, the two metal pins close the electrical contact through the water, transmitting a low voltage current to the PC Board.

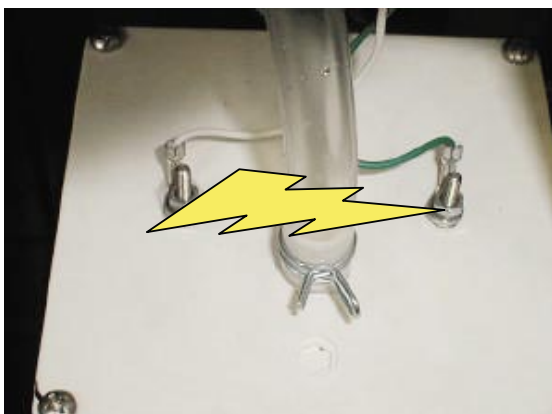

The PC Board activates the Water Drain Pump for 8 seconds pumping out most of the water contained into the Sealed Water Reservoir.

The water can be pumped out up to 1.5 m rise or

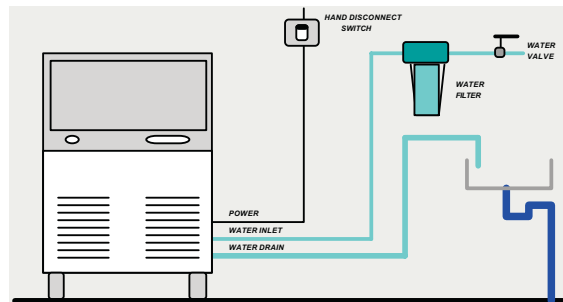

to 30 m on horizontal length.

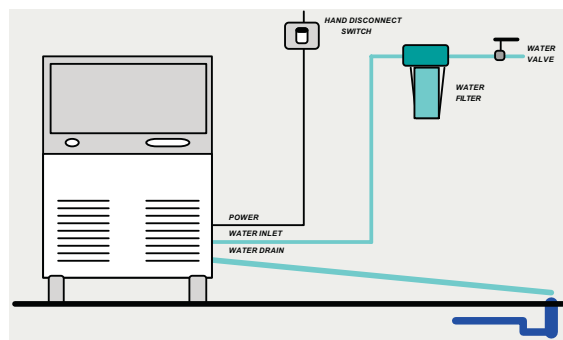

A Check Valve, located on the water drain hose, prevents the coming back of the discharged water.



SCHEMATIC SYSTEM

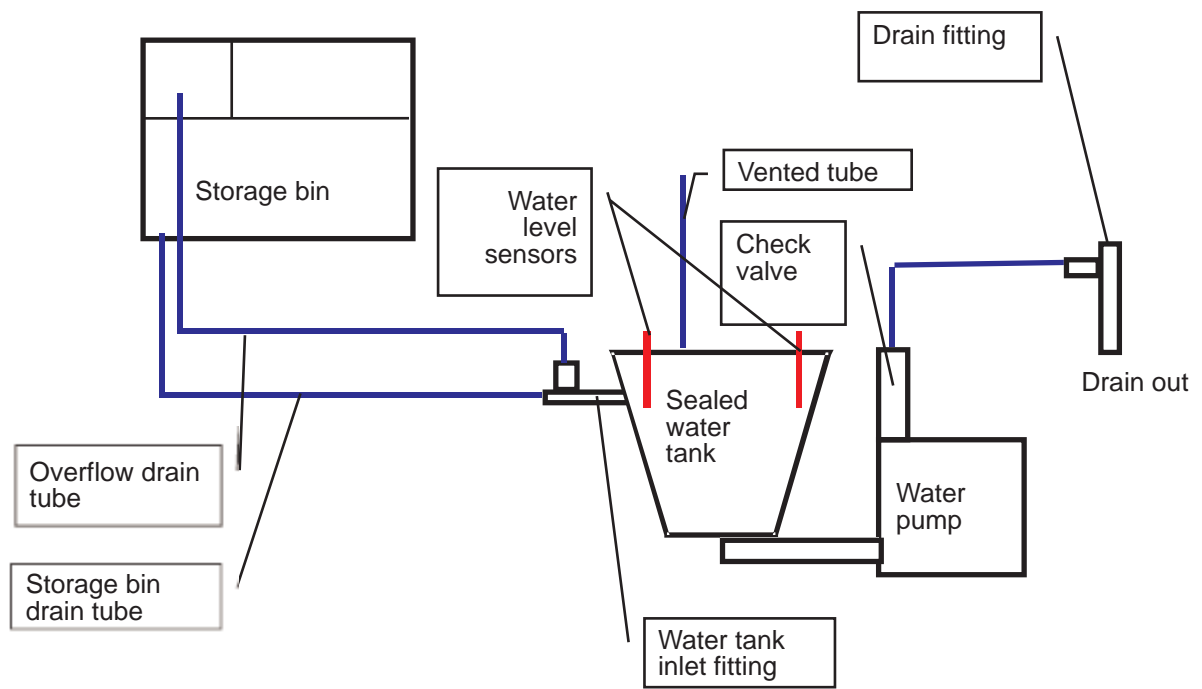

COMPONENTS DESCRIPTION

A. EVAPORATOR TEMPERATURE SENSOR

The evaporator temperature sensor probe, located in contact with the evaporator serpentine, detects the dropping of the evaporator temperature during the freezing cycle and signals it by supplying a current flow to the micro processor of P.C. BOARD.

According to the current received is energized the small Red LED of the PC Board (blink or steady).

When steady, the micro processor supplies power to the electronic timer built into the P.C. BOARD so that it takes control of the last portion of freezing cycle.

The length of the timed phase is pre-fixed by the setting of the keys 1, 2, 3 and 4 of the DIP SWITCH.

NOTE. *Whenever, after 15 minutes from the beginning of the freezing cycle, the evaporating temperature have not yet reached the value of 0°C (32°F) - small Red LED OFF - the P.C.Board switches OFF the machine with the BLINKING of WARNING RED LED.*

B. CONDENSER TEMPERATURE SENSOR

The condenser temperature sensor probe, located within the condenser fins (air cooled version) or in contact with the tube coil (water cooled version) detects the condenser temperature variations and signals them by supplying current, at low voltage, to the P.C. BOARD.

In the air cooled versions, in relation to the different current received, the micro processor of the P.C. BOARD supplies, through a TRIAC, the power at high voltage to the fan motor so to cool the condenser and to reduce its temperature.

In case the condenser temperature rises and reaches **70°C (160°F)** - on air cooled models - or **60°C (140°F)** - on water cooled models - the

current arriving to the micro processor is such to cause an immediate and total stop of the machine operation.

C. ICE LEVEL THERMAL PROBE

It operates in detecting both the low temperature of the ice and the mass near the bin sensing bulb.

D. ICE BIN LEVEL LIGHT CONTROL

The electronic ice bin level control, located into the storage bin, has the function to stop the operation of the ice machine **only at the end of the harvest cycle** when the light beam between the light source and the sensor is interrupted by the ice cubes stored into the bin.

When the light beam is interrupted the Bin Full YELLOW LED starts to blink; the ice machine stops with the glowing-up of the **Bin Full YELLOW LED** to monitor the situation of ice bin full at the end of the harvest cycle.

Six seconds after the scoop out of the ice (with the resumption of the light beam between the two infrared sensor of ice level control) the ice machine restarts again with the extinguishing of the YELLOW LED.

E. P.C. BOARD (Data processor)

The **P.C. BOARD**, fitted in its plastic box located in the front of the unit, consists of two separated printed circuits one at high and the other at low voltage integrated with fuse on power out (6.3 A), of four aligned **LEDS** monitoring the operation of the machine, of one extra monitoring **RED LED** (blink 0°C - steady - 15°C), of one **DIP SWITCH** with ten keys, of one push button, of input terminals for the leads of the sensor probes and input and output terminals for the leads of the ice maker electrical wires.

The P.C. BOARD is the brain of the system and it elaborates, through its micro processor, the signals received from the three sensors in order

to control the operation of the different electrical components of the ice maker (compressor, water pump, solenoid valves, etc.).

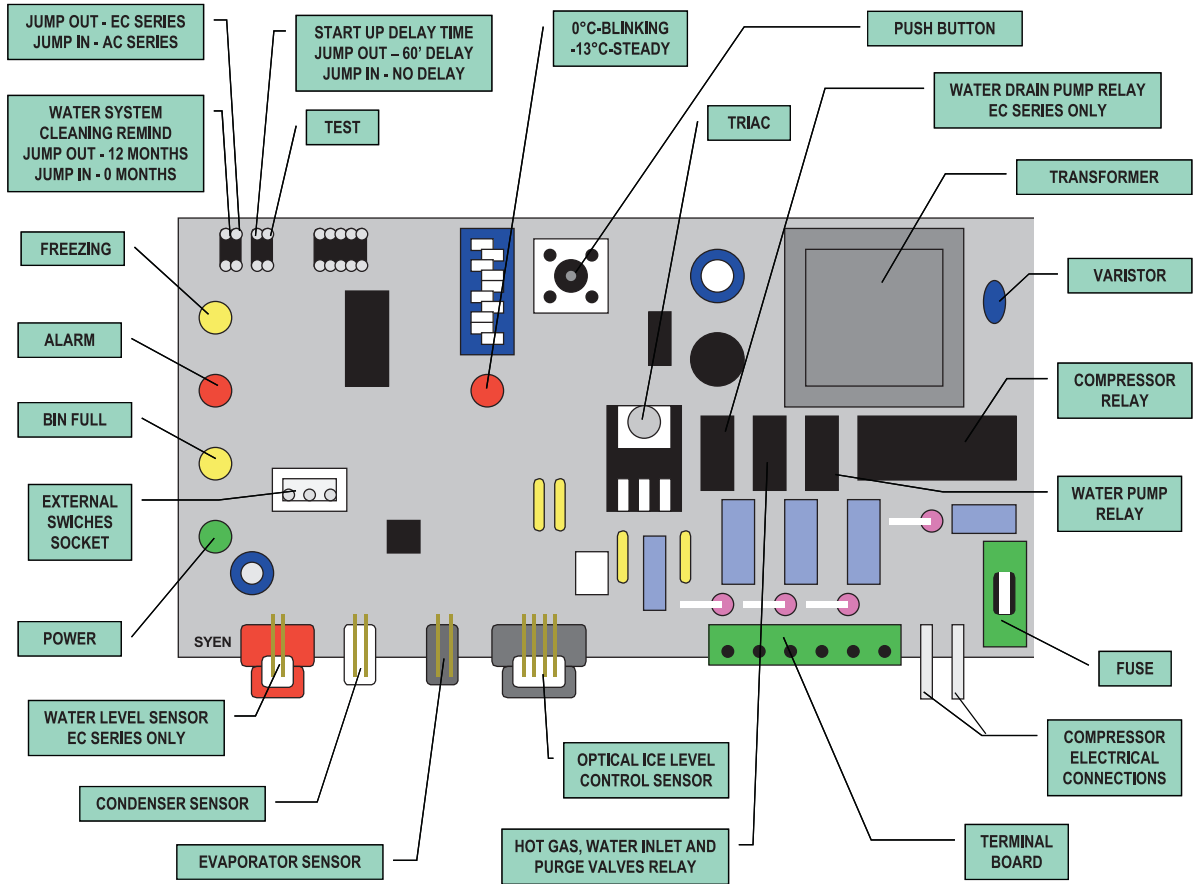

At restart, from any tripping OFF at Bin Full, the new PC Board assures 45 seconds water filling phase so to refill the water sump up to the maximum level.

In case of malfunction of the Optical Ice Level Control, the new PC Board switch ON alternativelt the Yellow and Red Led continuously.

On the PC Board there are four jumpers to select:

- 0 or 12 months remind time for the water system cleaning
- Operation of the Purge Out Water Pump (Jump IN on EC series)
- "no delay" or 60 minutes delay time at first start up
- TEST

In case the TEST contacts are closed with the Jumper, at the Start Up of the machine the PC Board energizes all the electrical components for maximum 3 minutes time.

At the end of the 3 minutes the PC Board switch OFF the entire machine with the blinking of all the LED's as shown on the bottom drawing.

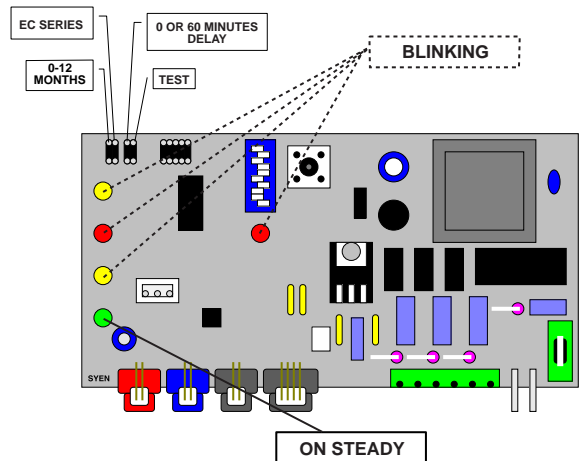

F. PUSH BUTTON OPERATION

DURING WATER FILLING PHASE

- Push for more then 2" but less then 5" the machine enters in Cleaning Mode
- Push for more then 5" the machine by-pass the Water Filling Phase

DURING FREEZING/HARVEST CYCLE

- Push for more then 5" during the Freezing cycle the machine goes immediately into Harvest
- Push for more then 5" during the Harvest cycle the machine enters immediately in the Freezing cycle

The length of Harvest is equal to:

- 35" if Push Button is activated before -15°C evaporating temperature LED activation
- As per Harvest cycle chart, if Push Button is activated after -15°C evaporating temperature LED activation (Red LED inside PC Board ON steady)

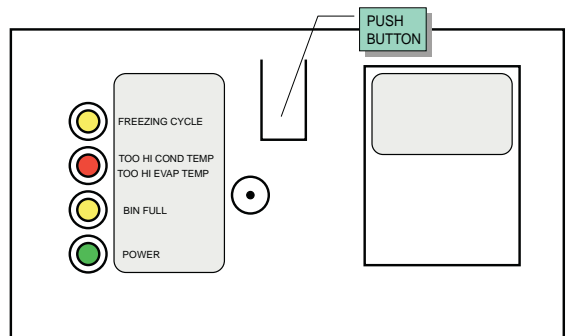

- Push more then 20" to restore remind cleaning timer.

G. LED MEANING

GREEN LED ON

Unit under power

YELLOW BIN FULL LED ON

Unit shut-OFF at storage bin full

YELLOW BIN FULL LED BLINKING

Infrared beam break out

RED ALARM LED ON

Too hi condensing temperature

RED ALARM LED BLINKING

Too hi evaporating temperature

YELLOW FREEZING CYCLE ON

Unit in freezing cycle mode

YELLOW FREEZING LED AND RED ALARM LED ON

Condenser sensor out of order

YELLOW FREEZING LED AND RED ALARM LED BLINKING

Evaporator sensor out of order

LED	STATUS	REASON WHY
	ON STEADY	UNIT UNDER POWER
	ON STEADY	FREEZING CYCLE
	BLINKING	60 MINUTES DELAY AT START UP JUMPER J3 OUT
	ON STEADY	TOO HI DISCHARGE PRESSURE/TEMP
	BLINKING	TOO HI EVAP. TEMP. (> 0C°) AFTER 15' FROM START UP
	ON STEADY	UNIT OFF AT BIN FULL
	BLINKING SLOW	I/R BEAM CUTTED
	BLINKING FAST	I/R ON AFTER TRIP OFF AT BIN FULL
	ON STEADY	I/R CALIBRATION DONE
	BLINKING	UNIT IN CLEANING MODE OR TRIPPING OFF AFTER TEST - JUMPER TEST IN
	ON STEADY	CONDENSER SENSOR OUT OF ORDER
	BLINKING	EVAPORATOR SENSOR OUT OF ORDER
	BLINKING ALTERNATIVELY	I/R SENSOR OUT OF ORDER

	<p>PUSH > 5" DURING WATER FILLING TO MOVE THE UNIT INTO FREEZING</p> <p>PUSH > 5" DURING FREEZING TO MOVE THE UNIT INTO DEFROST</p> <p>PUSH > 5" DURING DEFROST TO MOVE THE UNIT INTO FREEZING</p> <p>PUSH 2" > 5" DURING WATER FILLING TO MOVE THE UNIT INTO CLEANING</p> <p>PUSH DURING THE 60 MIN START UP DELAY TIME TO BY-PASS IT</p>
--	--

H. DIP SWITCH

The P.C.BOARD which controls the entire operation of the ice maker, has a **DIP SWITCH with ten switching keys** which allow to set up the micro processor program in order to extend or to shorten the length of freezing cycle in relation to the different model and versions of ice machines.

The DIP SWITCH first four keys setting determines the length of the 2nd phase of freezing cycle (controlled by the electronic timer) as detailed in the table B.

The DIP SWITCH keys 5 & 6 setting determines the length of the defrost cycle according to the

**O. WATER INLET SOLENOID VALVE -
3/4 MALE FITTING
(AC/EC 106 only)**

A second water inlet solenoid valve is used on water cooled version. An automatic hi pressure control activates the coil of the water inlet solenoid valve so to supply a metered amount of water to the condenser and drop down its temperature and pressure.

P. HOT GAS SOLENOID VALVE

The hot gas solenoid valve consists basically in two parts: the valve body and the valve coil. Located on the hot gas line, this valve is energized through the micro processor of P.C. BOARD during the defrost cycle as well as during the water filling phase. During the defrost cycle the hot gas valve coil is activated so to attract the hot gas valve piston in order to give way to the hot gas discharged from compressor to flow directly into the evaporator serpentine to defrost the formed ice cubes.

Q. FAN MOTOR (Air cooled version)

The fan motor is controlled through the P.C. BOARD and the TRIAC by the condenser temperature sensor. Normally it operates only during the freezing cycle to draw cooling air through the condenser fins. In the second part of the freezing cycle, the fan motor can run at intermittance as the condenser pressure must be kept between two corresponding head pressure values.

R. COMPRESSOR

The hermetic compressor is the heart of the refrigerant system and it is used to circulate and retrieve the refrigerant throughout the entire system. It compresses the low pressure refrigerant vapor causing its temperature to rise

and become high pressure hot vapor which is then released through the discharge valve.

**S. HI PRESSURE CONTROL
(AC/EC 106 only)**

Used only on the water cooled versions it operates to keep between pre-set values the hi-side or discharge pressure of the refrigerant system by energizing the coil of the water inlet solenoid valve that control the cooling water flow to the condenser.

**T. WATER REGULATING VALVE
(only on AC/EC 126-176-206-226)**

This valve controls the head pressure in the refrigerant system by regulating the flow of water going to the condenser. As pressure increases, the water regulating valve opens to increase the flow of cooling water.

**U. WATER DRAIN SOLENOID VALVE
(not on AC/EC 106)**

The water drain solenoid valve, electrically connected in parallel to the water inlet and to the hot gas solenoid valves, is energized for all the length of the defrost cycle. By means of the water pump, that remains energized for 15 seconds at the beginning of the defrost cycle, it allows the drain out of all remaining water (rich of minerals deposited during the previous freezing cycle) from the sump tank. By doing so it allows to the ice maker to make every new freezing cycle with new fresh water, avoiding thereby the accumulation of sediments and scales, which soon or later will cause the partial or total clogging of the water system on the unit.

ADJUSTMENT PROCEDURES

A. ADJUSTMENT OF THE CUBE SIZE

CAUTION. Before performing actual adjustment of the cube size, check other possible causes for cube size problems, refer to the Service Diagnosis Section for problem review and analysis. Do not perform any adjustment till the icemaking system has progressed through several complete freezing and harvest cycle, to observe size and quality of ice cubes and whether or not the cube size problem exists.

I. If the cubes are shallow size (Indentation is too deep) probably the length of the second phase of the freezing cycle is too short so, to extend such length you have to:

1. Locate the DIP SWITCH on the front of the P.C.Board.
2. Take note of the combination of the first four DIP SWITCH KEYS and check the corresponding length of freezing cycle 2nd phase on Table B.
3. Set the same DIP SWITCH KEYS to correspond to the prior combination shown on Table B which allow an extension of two more minutes of the length of the freezing cycle.
4. Observe the ice cubes in the next two harvests and eventually repeat steps 2 and 3 above until proper ice cubes size is achieved. See figure.

II. If the cubes are oversize size (Indentation is too full) probably the length of the second phase of the freezing cycle is too long. To shorten such length you have to:

1. Locate the DIP SWITCH on the front of the P.C.Board.
2. Take note of the combination of the first four DIP SWITCH KEYS and check the corresponding length of freezing cycle 2nd phase on Table B.
3. Set the same DIP SWITCH KEYS to correspond to the next combination shown on Table B which allow a reduction of two minutes of the length of the freezing cycle.
4. Observe the ice cubes in the next two harvests and eventually repeat steps 2 and 3 above until proper ice cubes size is achieved. See figure.

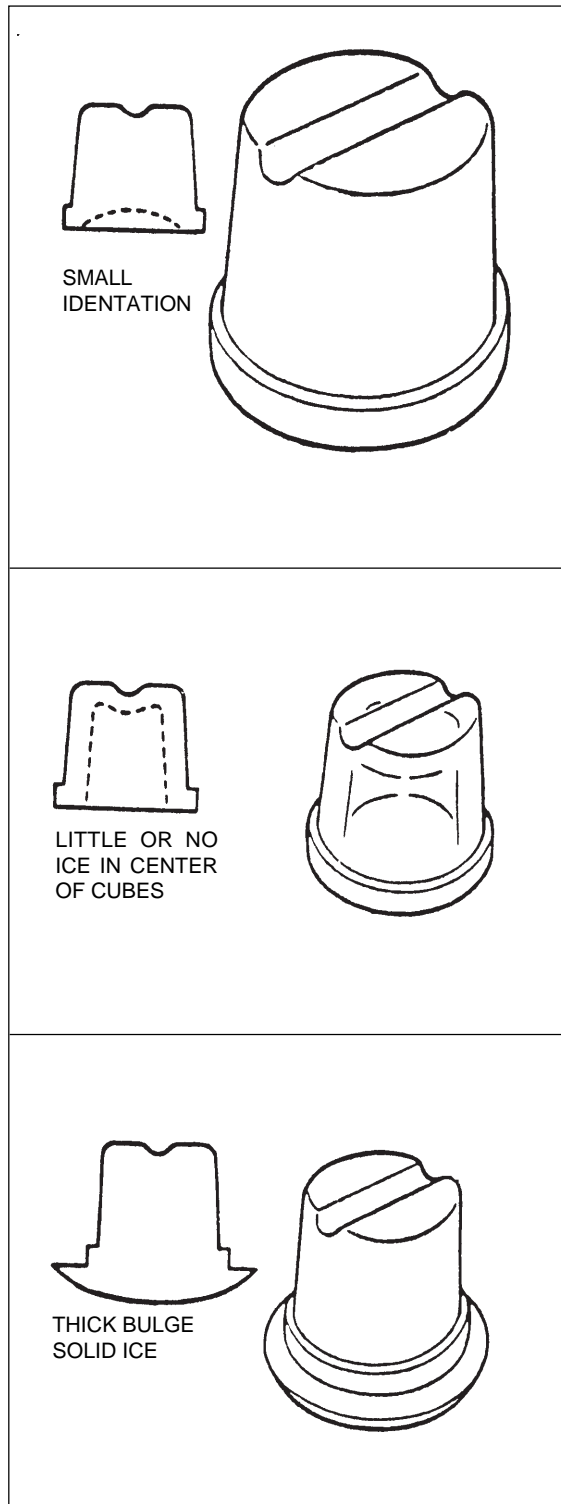

WIRING DIAGRAM







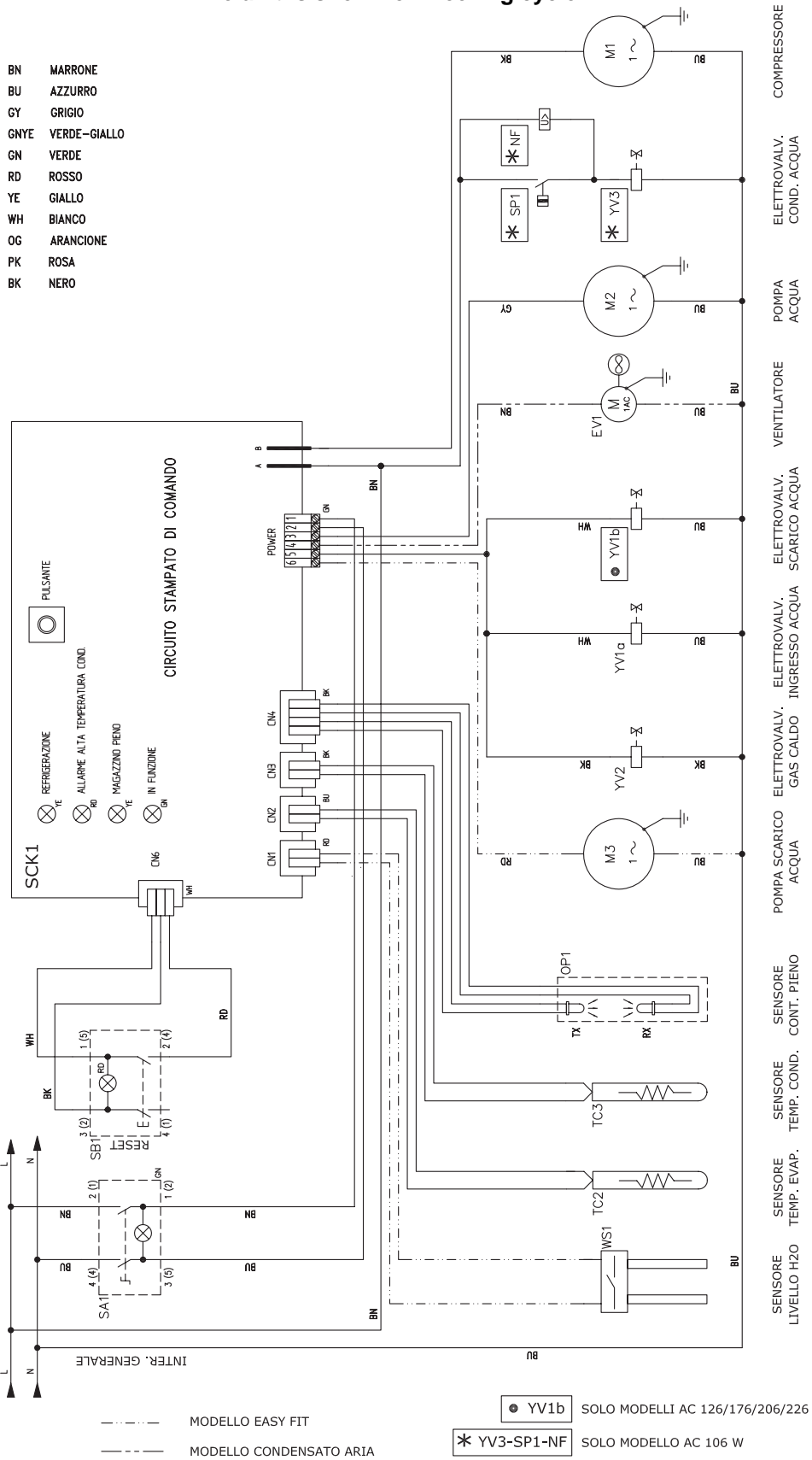









AC/EC 106-126-176-206-226 AIR AND WATER COOLED 230/50-60/1

The unit is shown on freezing cycle

- BN MARRONE
- BU AZZURRO
- GY GRIGIO
- GYE VERDE-GIALLO
- GN VERDE
- RD ROSSO
- YE GIALLO
- WH BIANCO
- OG ARANCIONE
- PK ROSA
- BK NERO



COMPRESSORE (M1)
 ELETTRIVALV. COND. ACQUA (YV3)
 POMP. ACQUA (M2)
 VENTILATORE (EV1)
 ELETTRIVALV. SCARICO ACQUA (YV1b)
 ELETTRIVALV. INGRESSO ACQUA (YV1a)
 ELETTRIVALV. GAS CALDO (YV2)
 POMP. SCARICO ACQUA (M3)
 SENSORE TEMP. COND. CONT. PIENO (TC3)
 SENSORE TEMP. EVAP. (TC2)
 SENSORE LIVELLO H2O (WS1)
 SENSORE CONT. PIENO (OP1)

Sim.\Sym.	Sigla \Item	Funzione \Use Type	Sim.\Sym.	Sigla \Item	Funzione \Use Type	Sim.\Sym.	Sigla \Item	Funzione \Use Type
	EV1	Ventilatore		TC3	Sensore temperatura condensatore			
	M1	Compressore		WS1	Sensore livello acqua			
	M2	Pompa acqua		YV2	Elettrovalvola gas caldo			
	M3	Pompa scarico acqua		YV1a	Elettrovalvola ingresso acqua			
	NF	Filtro antidisturbo		YV1b	Elettrovalvola scarico acqua			
	OP1	Sensore contenitore pieno		YV3	Elettrovalvola cond. acqua			
	SA1	Interruttore generale						
	SB1	Pulsante di reset						
	SCK1	Circuito stampato di comando						
	SP1	Pressostator ventilatore						
	TC2	Sensore temperatura evaporatore						

SERVICE DIAGNOSIS

SYMPTOM	POSSIBLE CAUSE	SUGGESTED CORRECTION
Unit will not run (No warning LEDS glows)	Blown power in fuse in P.C.Board Main switch in OFF position Inoperative P.C.Board Loose electrical connections	Replace fuse & check for cause of blown fuse Turn switch to ON position Replace P.C.Board Check wiring
(Green LED-Power ON glows)	Blown power out fuse in P.C. Board	Replace fuse & check for cause of blown fuse
(Bin full LED glows)	Inoperative ice level control Inoperative P.C.Board	Clean or replace ice level control Replace P.C.Board
(Red-alarm LED-LIGHT glows)	High head pressure	Inoperative fan motor. Replace Shortage of water (WC)
(Red-alarm LED blinks)	High evaporating temperature after 15 mins. beginning freeze	Hot gas valve leak - Replace it. Water inlet valve leak - Replace it. Short of refrigerant. Compressor cycles intermittently
(Freezing LED + Red-alarm LED glows) and Red-alarm Light blinks twice and repeat	Condenser sensor out of order	Replace it
(Freezing LED + Red-alarm LED blinks)	Evaporator sensor out of order	Replace it
Compressor cycles intermittently	Low voltage Non-condensable gas in system Compressor starting device with loose wires Mechanical problem	Check circuit for overloading Check voltage at the supply to the building. If low, contact the power company Purge the system Check for loose wires in starting device Replace compressor
Cubes too small	Freezing cycle too short Capillary tube partially restricted Moisture in the system Shortage of refrigerant	Review setting of DIP SWITCH keys Blow charge, add new gas & drier, after evacuating system with vacuum pump Same as above Check for leaks & recharge
Cloudy cubes	Shortage of water Dirty water supply Accumulated impurities	See remedies for shortage of water Use water softner or water filter Use SCOTSMAN Ice Machine cleaner

SERVICE DIAGNOSIS

SYMPTON	POSSIBLE CAUSE	SUGGESTED CORRECTION
Shortage of water	Water spilling out through curtain Water solenoid valve not opening Water leak in sump area Water flow control plugged Leak of water drain valve	Check or replace curtain Replace valve Locate and repair Replace water inlet valve Replace valve
Irregular cubes size & some cloudy	Some jets plugged Shortage of water Unit not level	Remove jet cover and clean See shortage of water Level as required
Cubes too large	Freezing cycle too long	Review setting of DIP SWITCH keys
Decreased ice capacity	Inefficient compressor Leaky water valve Non-condensable gas in system Poor air circulation or excessive hot location (Red-alarm LED glows) Overcharge of refrigerant Capillary tube partially restricted Hot gas solenoid valve leaking Short of refrigerant Discharge head pressure too high	Replace Repair or replace Purge the system Relocate the unit or provide for more ventilation Correct the charge. Purge off slowly Blow charge, add new gas & drier, after evacuating system with vacuum pump Replace valve Charge to data plate indication See incorrect discharge pressure
Poor harvest	Restriction in incoming water line Water inlet valve not opening Hot gas valve orifice restricted Clogged air vented holes in mold cups Discharge head pressure too low	Check water valve strainer and flow control. If necessary enlarge the flow control orifice Valve coil with open winding Replace valve Replace hot gas valve assy Clean out holes plugged See incorrect discharge pressure

SERVICE DIAGNOSIS

SYMPTON	POSSIBLE CAUSE	SUGGESTED CORRECTION
Unit won't harvest	Inoperative P.C.Board Hot gas valve not opening Water solenoid valve not opening	Replace P.C.Board Valve coil with open winding Replace valve Valve coil with open winding Replace valve
Incorrect discharge pressure	Inoperative condenser sensor Inoperative P.C.Board Water regulating valve misadjusted	Replace sensor Replace P.C.Board Adjust its setting stem
Excessive water in unit base	Water tubing leaking	Check. Tighten or replace

MAINTENANCE AND CLEANING INSTRUCTIONS

A. GENERAL

The periods and the procedures for maintenance and cleaning are given as guides and are not to be construed as absolute or invariable. Cleaning, especially, will vary depending upon local water and ambient conditions and the ice volume produced; and, each icemaker must be maintained individually, in accordance with its particular location requirements.

B. CLEAN - REPLACE OF AIR CONDENSER FILTER

NOTE. The new AC series, in the air cooled version, are standard equipped with an air condenser filter as well as a Cleaning Reminder Board to remind to the end user the need for the cleaning of the air filter or of the water system (Red Alarm Light ON Steady or Blinking respectively with machine in operation).

1. Withdraw the air filter from the front through the opening of the front panel.
2. Blow pressurised air on the opposite direction of the condenser air flow so to remove the dust accumulated.
3. If pressurised air is not available, use tap water always in the counter flow air direction.
Once cleaned shake it so to remove most of the accumulated water, then dry it using an hair dryer.

NOTE. In case the air filter strainer is damaged replace it with a new one.

4. Install it again by pushing it through the front panel opening.

A. ICEMAKER

The following maintenance should be scheduled at least two times per year on these icemakers.

1. Check and clean the water line strainer.
2. Check that the icemaker is levelled in side

to side and in front to rear directions.

3. Check for water leaks and tighten drain line connections.
Pour water down bin drain line to be sure that drain line is open and clear.

4. Check size, condition and texture of ice cubes. Perform adjustment of cube size control as required.

5. Check the ice level control sensor to test shut-off. Put your hand between the light source and the receiver so to cut off the light beam for at least one minutes.

This should cause the ice maker to shut off and the light up of the 2nd LED (yellow light) a the end of defrost cycle.

NOTE. Within few seconds after the removal of the hand from the Infrared sensing light the icemaker restarts in freezing cycle. The ice level control uses devices that sense light, therefore they must be kept clean enough so they can "see". Every month clean/wipe the sensing "eyes" with a clean soft cloth.

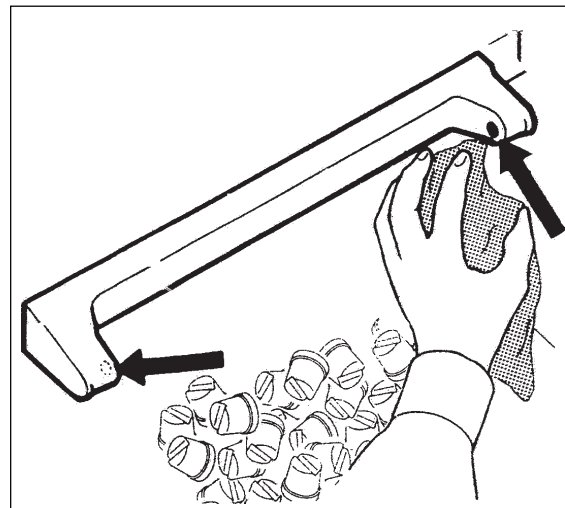

6. Check for refrigerant leaks.

B. CLEANING/SANITISING INSTRUCTIONS OF WATER SYSTEM

Clean-sanitise the water system, evaporator, bin and spray jets using a solution of SCOTSMAN Ice Machine Cleaner/Sanitizer.

NOTE. Cleaning requirements vary according to the local water conditions and individual user operation. Continuous check of the clarity of ice cubes and visual inspection of the water spraying parts before and after cleaning will indicate frequency and procedure to be followed in local areas.

1. Remove the front and top panels to gain access either to the control box and to the evaporator.
2. Make sure that all ice cubes have been released from their cups, then switch OFF the machine at front master button switch.
3. Scoop out all the ice cubes stored into the bin in order to prevent them from being contaminated with the cleaning solution.
4. Remove the plastic cup located on the bottom of sump/freezing chamber to drain out all water and scale deposits.



5. Lift up and remove the curtain.

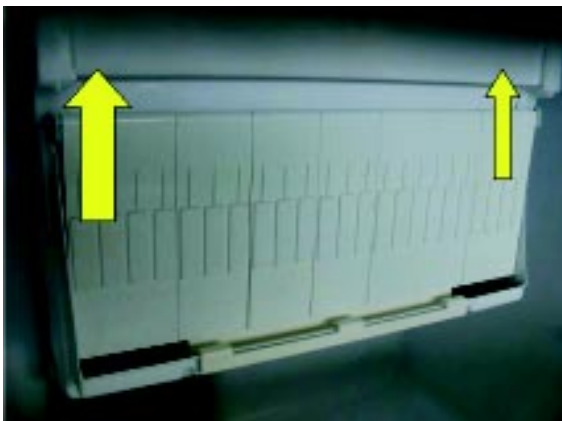

6. Lift up the entire spray platen from its bottom seat and take it out to clean it separately.

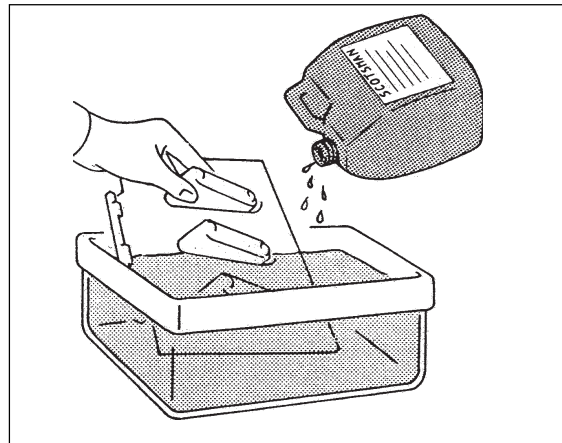

7. Using a bottle, pour fresh water into the bottom of the sump/freezing chamber to clean out most of scale deposit.
8. Install again the spray platen, the curtain as well as the bottom plastic cup.

Cleaning

9. Prepare the cleaning solution by diluting in a plastic container two liters of warm water (45°-50°C) with 0,2 liters of Ice Machine Cleaner.

WARNING. The SCOTSMAN Ice Machine Cleaner contains Phosphoric and Hydroxyacetic acids. These compounds are corrosive and may cause burns if swallowed, DO NOT induce vomiting. Give large amounts of water or milk. Call Physician immediately. In case of external contact flush with water. KEEP OUT OF THE REACH OF CHILDREN.

10. Remove the evaporator cover then slowly pour onto the evaporator platen the cleaning solution. With the help of a brush dissolve the most resistant and remote scale deposits in the platen.
11. Switch ON again the machine at front master button switch then push the PC BOARD

PUSH BUTTON for more than 2" and less of 5" to put the machine in cleaning mode.

NOTE. With the system in **CLEANING/RINSING** mode the water pump is the only component in operation to circulate the cleaning solution in the entire water system while the three leds of the PC Board are blinking (Fig. 8).

12. Let the unit to remain in the **CLEANING** mode for about 20 minutes then unplug again the machine.

NOTE. The amount of Cleaner and the time needed for the cleaning of water system depends of the water conditions.

13. Switch OFF the ice maker at master button switch then flush out the cleaning solution from the sump reservoir by taking off the sump plastic cup. Once flushed out install again the sump plastic cup.

14. Pour onto the evaporator cavity two or three liters of clean potable water to rinse the mold cups and the platen.

15. Switch ON again the machine. The water pump is again in operation to circulate the water in order to rinse the entire water system. Do the operation as per steps 13 and 14 twice so to be sure no more traces of descaling solution remains into the sump.

REMEMBER. To prevent the accumulation of undesirable bacteria it is necessary to sanitize the interior of the storage bin with an anti-algae disinfectant solution every week.

Sanitation

NOTE. Sanitation of the water system is recommended to be done **once a month**.

1. Prepare in a plastic container the sanitation solution as per manufacturer dilution using warm water (45-50 °C).

NOTE. Never mix the cleaning with the sanitising solution.

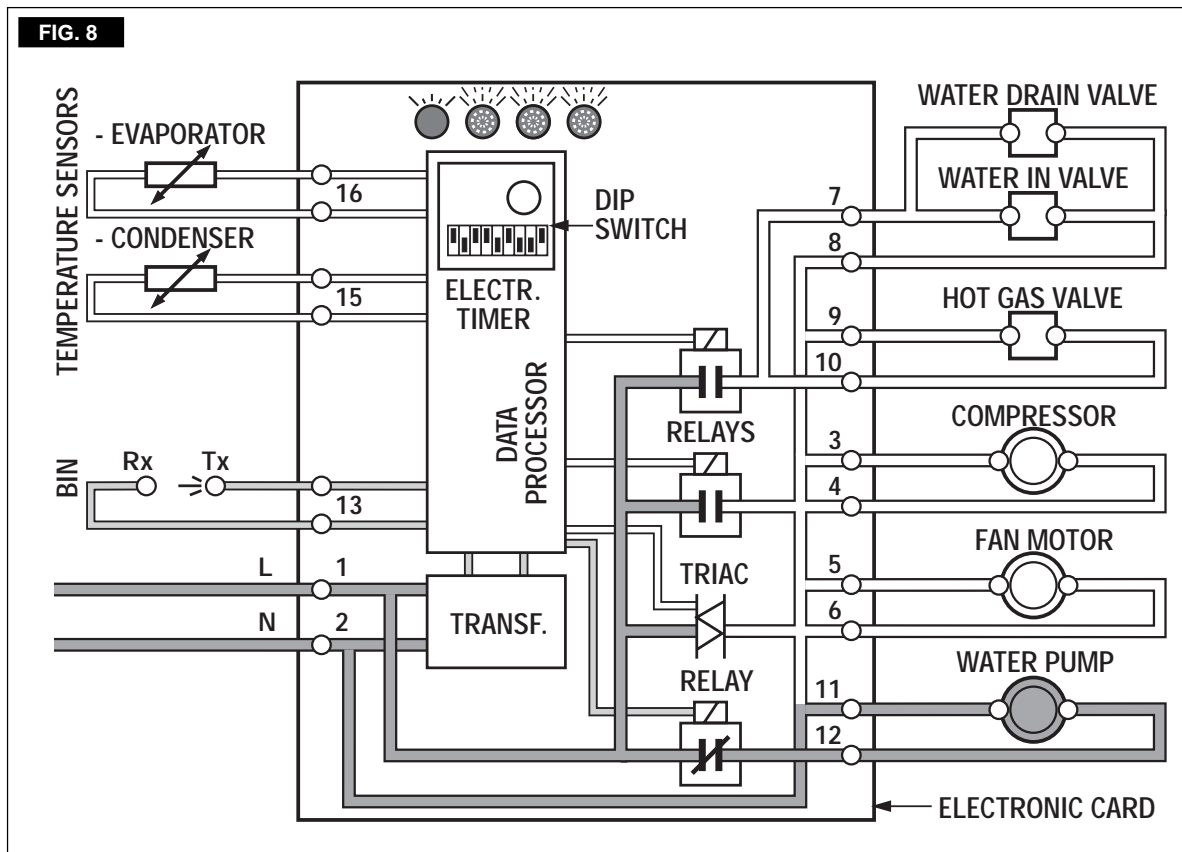

2. Follow the procedures as per cleaning water pump operation, only by keeping pushed Reset button between 2 ÷ 5" during water filling. Just shorting the operation of the water pump to 10 minutes.
3. Place again the evaporator cover and the unit service panels.
4. At completion of the freezing and harvest cycle make sure of proper texture and clearness of the ice cubes and that, they do not have any acid taste.

ATTENTION. In case the ice cubes are cloudy-white and have an acid taste, melt them immediately by pouring on them some warm water. This to prevent that somebody could use them.

5. Wipe clean and rinse the inner surfaces of the storage bin.

REMEMBER. To prevent the accumulation of undesirable bacteria it is necessary to sanitize every week the interior of the storage bin.

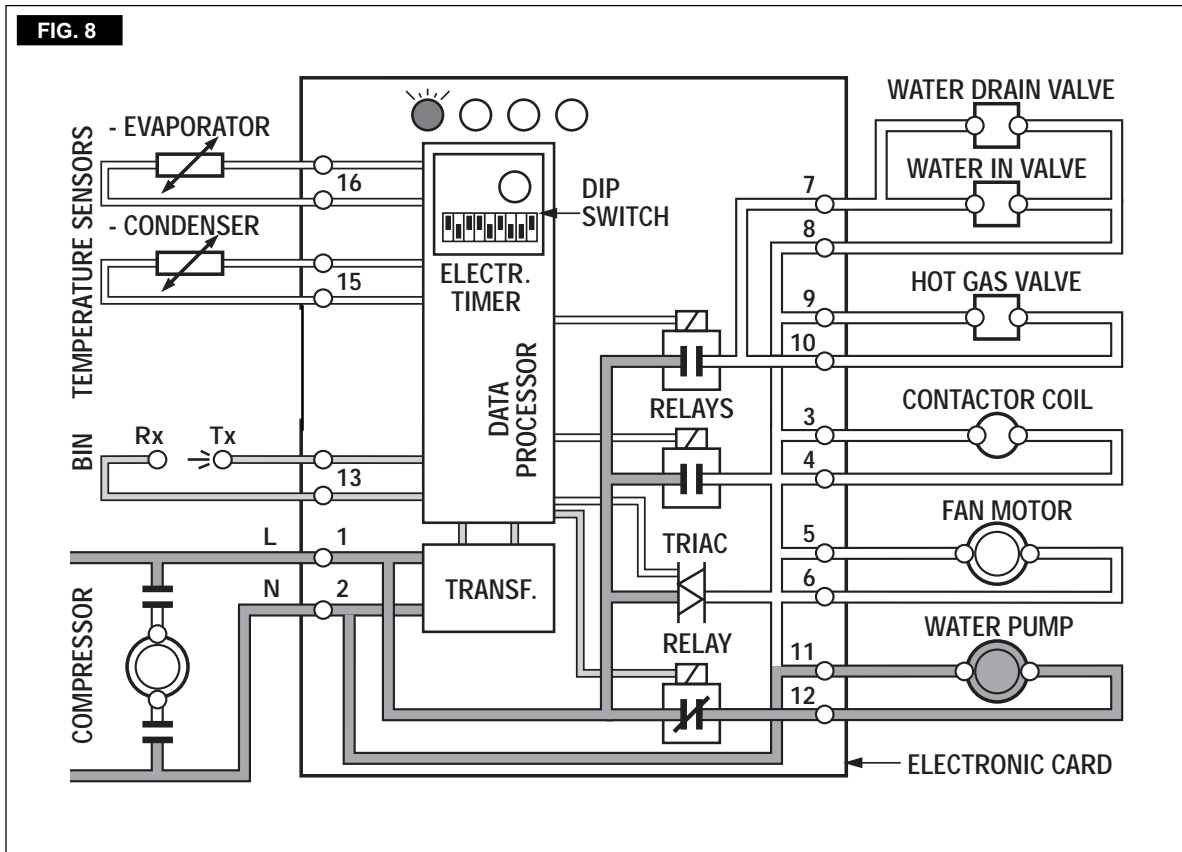

AC 206-226

B. ICEMAKER

The following maintenance should be scheduled at least two times per year on these icemakers.

1. Check and clean the water line strainer.
2. Check that the icemaker is levelled in side to side and in front to rear directions.
3. Clean the water system, evaporators, bin and spray bar/s using a solution of SCOTSMAN Ice Machine Cleaner. Refer to procedure C cleaning instructions and after cleaning will indicate frequency and procedure to be followed in local areas.
4. Reach the water spray bar from the inside of the freezing chamber lifting it from its seat with its bottom race washer.

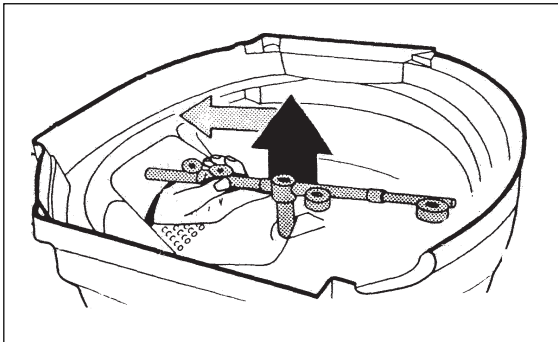

Dip it into a tray filled with cleaning solution then rinse it under a tap water stream.

With a pick clean the orifice of the water stream jet that propells the spray bar.

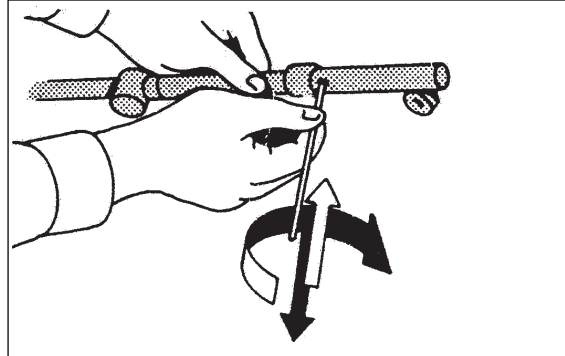

NOTE. Cleaning requirements vary according to the local water conditions and individual user operation. Continuous check of the clarity of ice cubes and visual inspection of the water spraying parts before and after cleaning will indicate frequency and procedure to be followed in local areas.

5. With the ice machine and fan motor OFF on air cooled models, clean condenser using vacuum cleaner, whisk broom or non metallic brush taking care to do not damage both the condenser and ambient temperature sensor probes.

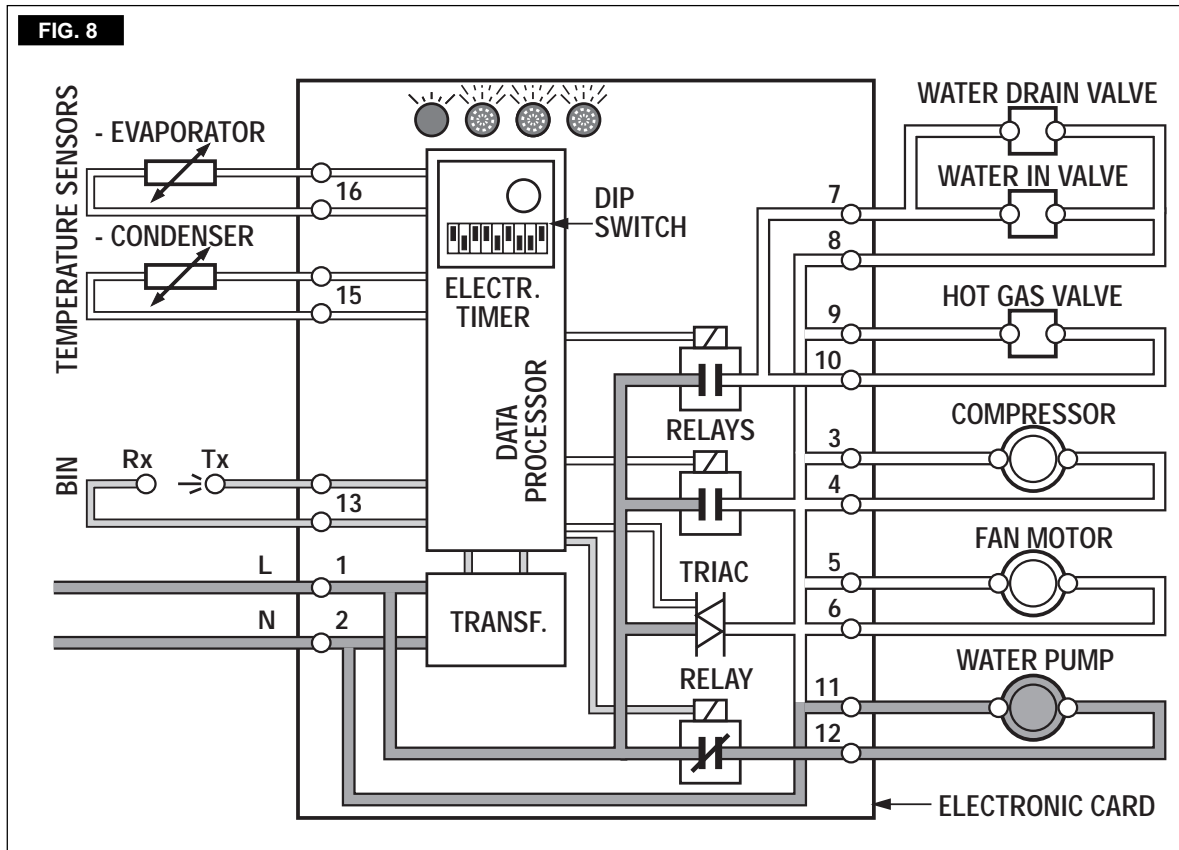

- 6. Check for water leaks and tighten drain line connections. Pour water down through the storage bin drain line to be sure that drain line is open and clear.
- 7. Check size, condition and texture of ice cubes. Perform adjustment of DIP SWITCH keys as required.
- 8. Check the ice level control sensor to test shut-off. Put some ice cubes between the light source and the receiver so to cut off the light beam for at least one minutes. This should cause the ice maker to shut off and the light-up of the 2nd LED (yellow light) at the end of defrost cycle.

IMPORTANT. Perform the above check only at the end of harvest cycle or at the beginning of freezing cycle in order to do not cause to the unit to make a double freezing cycle.

NOTE. Within few seconds after the removal of the ice cubes from the Infrared sensing light the icemaker restarts in **freezing cycle**. The ice level control uses devices that sense light, therefore they must be kept clean enough so they can "see". Every month clean/wipe the sensing "eyes" with a clean soft cloth.

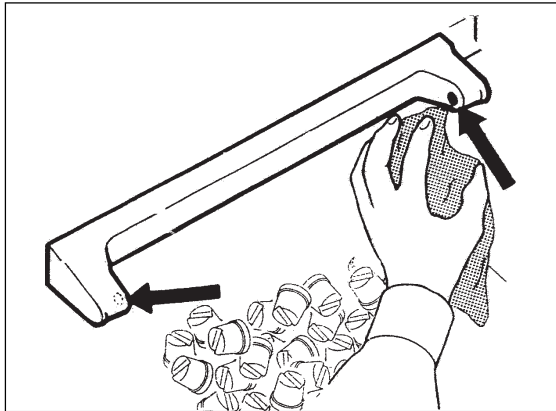

- 9. Check for refrigerant leaks.

C. CLEANING INSTRUCTIONS OF WATER SYSTEM

- 1. Remove left, center and right front panels to gain access either to the control box and to the evaporator.
- 2. Wait till the end of defrost cycle then turn the unit OFF by the main switch (disconnect power supply).
- 3. Prepare for each freezing chamber the cleaning solution by diluting in a plastic container

two or three liters of warm water (45°-50°C) with a 0,2-0,3 liters of **SCOTSMAN** Ice Machine Cleaner.

WARNING. The **SCOTSMAN** Ice Machine Cleaner contains **Phosphoric and Hydroxyacetic acids**. These compounds are **corrosive** and may cause burns if **swallowed, DO NOT induce vomiting. Give large amounts of water or milk. Call Physician immediately. In case of external contact flush with water. KEEP OUT OF THE REACH OF CHILDREN**

- 4. Scoop out all the ice cubes stored into the bin in order to prevent them from being contaminated with the cleaning solution then flush out the water from the sump reservoir by bending down the vertical sump drain hose.
- 5. Remove the evaporator cover then slowly pour onto the evaporator piaten the cleaning solution- With the help of a brush dissolve the most resistant and remote scale deposits in the platen. Perform the same for all the four evaporators.
- 6. Give power to the unit by the main switch.
- 7. During the Water Filling Phase push **RESET BUTTON** for more then 2" but less then 5" the machine enter in Cleaning Mode (Fig.7)

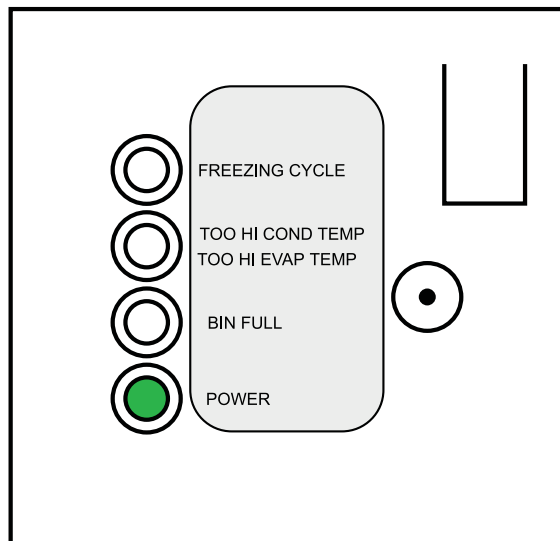

- 8. With the system in Cleaning mode the water pump is the only component in operation to circulate the cleaning solution in the entire water system
- 9. Let the unit remain in the cleaning mode for about 20 minutes then turn the main switch to OFF (disconnect unit from POWER)

10. Flush out the cleaning solution from the sump reservoirs then pour onto each evaporator cavity two or three liters of clean potable water with a capfull of antibacteria solution to rinse and sanitize the mold cups and the platen. If necessary remove the water spray bar to clean it separately as per steps 3 and 4 of paragraph B.

11. Give power to the unit by the main switch

12. During the Water Filling Phase push **RESET BUTTON** for more then 2" but less then 5" the machine enter in Rinsing Mode (Fig.7)

13. Let the unit remain in the RINSING MODE mode for about 10 minutes then turn the main switch to OFF (disconnect unit from POWER)

14. Flush out the rinsing solution from the sump reservoirs

15. Place again the evaporator cover and the unit service panels.

16. Give POWER to the unit.

17. At completion of the freezing and harvest cycle make sure of proper texture and clearness of the ice cubes and that, they do not have any acid taste.

ATTENTION. in case the ice cubes are cloudy, white and have an acid taste, melt them immediately by pouring on them some warm water. This to prevent that somebody could use them.

18. Wipe clean and rinse the inner surfaces of the storage bin.

REMEMBER. To prevent the accumulation of undesirable bacteria it is necessary to sanitize the interior of the storage bin with an anti-algae disinfectant solution every week.

Sanitation

NOTE. Sanitation of the water system is recommended to be done **once a month**.

19. Prepare in a plastic container the sanitation solution as per manufacturer dilution using warm water (45-50 °C).

NOTE. Never mix the cleaning with the sanitising solution.

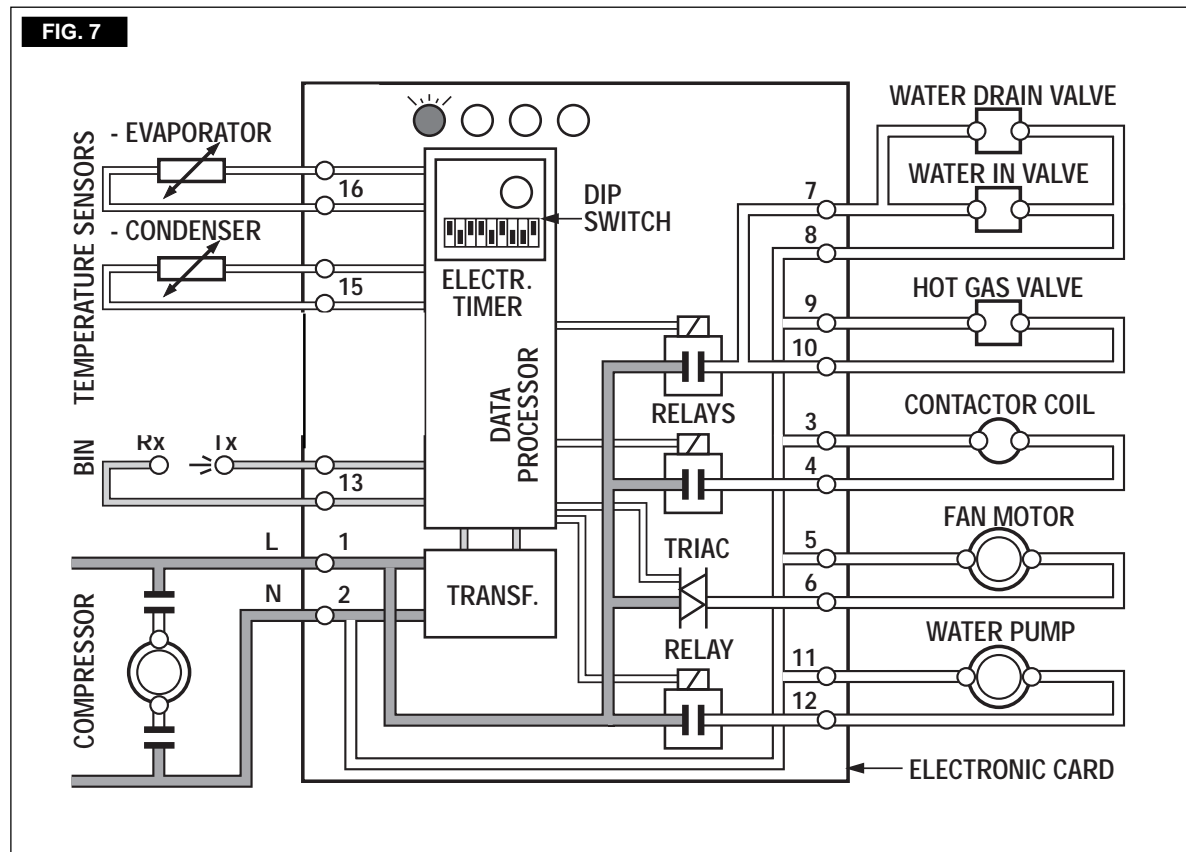

20. Follow the procedures as per cleaning water pump operation, only by keeping pushed Reset button between 2 ÷ 5" during water filling. Just shorting the operation of the water pump to 10 minutes.

21. Place again the evaporator cover and the unit service panels.

22. At completion of the freezing and harvest cycle make sure of proper texture and clearness of the ice cubes and that, they do not have any acid taste.

ATTENTION. In case the ice cubes are cloudy-white and have an acid taste, melt them immediately by pouring on them some warm water. This to prevent that somebody could use them.

23. Wipe clean and rinse the inner surfaces of the storage bin.

REMEMBER. To prevent the accumulation of undesirable bacteria it is necessary to sanitize every week the interior of the storage bin.

